

PRINCIPLE OF OPERATION

Perma Pure's heated MDH-Series gas dryers were specifically created to dry gas samples with dew points higher than ambient temperature without requiring separate heating elements or insulation. Proprietary Nafion technology selectively removes only water from sample gases, leaving the rest of the gas sample unaffected. Unlike chillers and condensers, Perma Pure's MDH dryers remove water directly from the vapor phase, preventing the loss of water-soluble gases through dissolution in condensate.

Designed to handle gas flows of up to 1.5 lpm, the heated MDH-Series gas dryers can dry gases with as much as 30% water by volume. The compact design can be incorporated easily into analyzer cabinets or used as a stand-alone device. The dryers are currently available for use with 110 VAC.

MDH™-Series gas dryer units consist of a Perma Pure MD-Series dryer encased in a housing with half of the dryer heated to a constant temperature of 80°C to prevent condensation.

The dryer consists of a single Nafion® tube within a fluorocarbon shell. Dry purge gas flowing over the exterior surface of the Nafion tubing continuously extracts water vapor from the gas stream inside the tubing. The driving force is the difference in water concentration on the opposite side of the tubing wall. The purge gas then carries the water vapor away.

MDH™ - Series Gas Dryer

User Manual



8 Executive Drive
Toms River, N.J. 08755
Phone: 732/244-0010
Fax: 732/244-8140
e-mail: info@permapure.com
Web Site: www.permapure.com

INSTALLATION GUIDELINES

When installing MDH-Series gas dryers, the following rules apply:

- Sample pressure higher or equal to purge pressure
 - Sample gas pressure not to exceed 80 psig and 10 psig for purge gas
 - Purge air of -40°C dew point at a flow rate of 15 times sample flow
 - Purge air must flow countercurrent to sample
-

Model Number: MDH-110-96F-4

Nafion Tube OD/ID: 0.108"/0.086"

Length: 96 inches

Nafion Dryer Housing: Fluorocarbon

Enclosure: Polycarbonate

Thermostat Set Point: 80° C

Power Requirements: 110 VAC, 0.3 Amps, 30 Watts

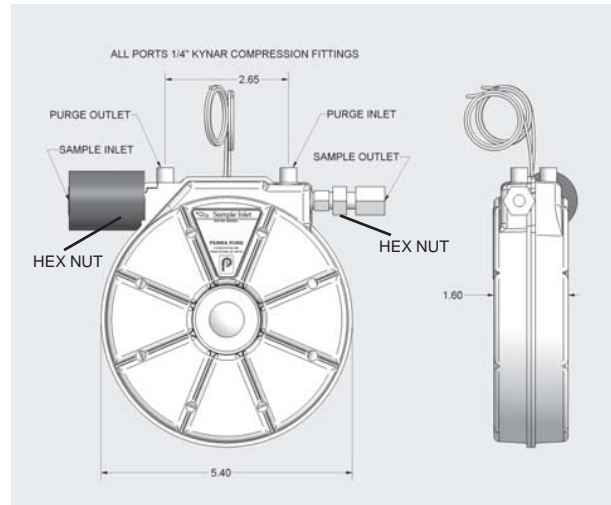

Figure 1

SETUP

(Refer to Figure 1)

1. Connect the 2 wires to a 110 VAC power source and let the unit heat for 15 minutes
2. Secure sample inlet and outlet connections using insulated fitting for sample inlet
3. Connect purge inlet and outlet fittings
4. Start purge flow (purge air must be -40°C dew point air, nitrogen or other gas)
5. Start sample flow. Sample must be maintained at constant temperature from its origin to prevent condensation

WARNING

Do not obstruct vent holes

TROUBLESHOOTING

If condensation forms in the unit:

- Decrease or stop sample flow and increase purge flow until unit dries out

If unit does not heat:

- Check wiring connections
- Confirm power source is operating