



eCOOL™ 5000 Series Digital Thermo-Electric Cooler Instruction Manual



Tel: 732-244-0010
Tel: 800-337-3762(toll free US)
Fax: 732-244-8140
Email: info@permapure.com
Web: www.permapure.com



TABLE OF CONTENTS

A: SPECIFICATIONS	4
B: LIMITED WARRANTY	5
C: PRINCIPLE OF OPERATION	6
D: INSTALLATION	9
E: START-UP PROCEDURE.....	10
F: LEDS & LCD	11
G: BOARDS	12
H: DEFAULT SETPOINTS.....	17
I: “NEW JERSEY” THERMOCOUPLE OPTION	18
J: MAINTENANCE.....	19
K: TROUBLESHOOTING	20
L: SPARE PARTS: ECOOL™ 5000	22
APPENDIX: ECOOL 5000™.....	25

A: SPECIFICATIONS

Model Specifications

Model	Standard Capacity	Heat Exchangers		Dimensions	Weight	Power Supply
		Passive	Active			
e5300	0-3 LPM 0-6 SCFH	1x5 in.	1x5 in.	11 x 7 x 11 in. HWD 29 x 18 x 29 cm HWD	20 lbs 9 kg	100W
e5400	3-4 LPM 6-8 SCFH		2x5 in.	11 x 7 x 11 in. HWD 29 x 18 x 29 cm HWD	20 lbs 9 kg	240W
e5500	4-7 LPM 8-15 SCFH	1x10 in.	1x10 in.	14 x 13 x 13 in. HWD 36 x 33 x 33 cm HWD	37 lbs 17 kg	240W
e5500XP	4-7 LPM 8-15 SCFH	1x10 in.	1x10 in.	14 x 13 x 13 in. HWD 36 x 33 x 33 cm HWD	39 lbs 18 kg	240W
e5800	7-10 LPM 15-21 SCFH		2x10 in.	14 x 13 x 13 in. HWD 36 x 33 x 33 cm HWD	37 lbs 17 kg	500W
e5800XP	7-10 LPM 15-21 SCFH		2x10 in.	14 x 13 x 13 in. HWD 36 x 33 x 33 cm HWD	39 lbs 18 kg	500W
e5900	10-20 LPM 21-42 SCFH	2x10 in.	2x10 in.	14 x 13 x 13 in. HWD 36 x 33 x 33 cm HWD	39 lbs 18 kg	500W
e5900XP	10-20 LPM 21-42 SCFH	2x10 in.	2x10 in.	14 x 13 x 13 in. HWD 36 x 33 x 33 cm HWD	41 lbs 19 kg	500W

General Specifications

Digital Boards	Main control board Water slip alarm relay board LAN card (optional) Filter probe & heated sample line accessory board (optional) Heat exchanger thermocouple isolated output board (optional)
Alarms	Probe over / under temperature Heated sample line over / under temperature Cooler over temperature Cooler thermocouple failure Water slip (moisture carryover)
Display	Jumbo dual-line LCD LED red, amber, green heat exchanger status indicators
Heat Exchanger Type	EZ-Clean™ twist apart
Heat Exchanger Material	Stainless steel (standard); Durinert® treated stainless steel, Kynar®, Glass (optional)
Heat Exchanger Connections	1/4" FNTF Inlet (first heat exchanger) 1/8" FNTF Outlet 3/8" FNTF Drain
Heat Sink Voltage	High heat transfer aluminum 110/120 VAC, 220/240 VAC, 12 VDC, 15 VDC, 24 VDC

Digital Board Specifications

Main Control Board	4 thermocouple inputs 4 analog outputs
Water Slip Alarm Relay Board	2 water slip (moisture carryover) inputs 2 high current digital contact outputs 2 digital PLC outputs
LAN card (optional)	Modbus or TCP/IP RJ45 / CAT 5 cable
Filter Probe & Heated Sample Line Accessory Board (optional)	2 thermocouple inputs Pulse width modulated digital output
Heat Exchanger Thermocouple Isolated Output Board (optional)	2 thermocouple inputs 2 x 4-20mA outputs 2 x 0-10VDC outputs

Operating Specifications

Maximum Inlet Sample Temperature	400°F (205°C) SS, Durinert®, Glass Impingers 280°F (138°C) Kynar® Impingers
Maximum Inlet Pressure	45 psig 3 bar / 2250 mmHg
Maximum Heat Exchanger Pressure Drop	<+1 in. H2O
Ambient Temperature Range	33-104°F 0.6-40°C
Outlet Sample Gas Dew Point	41°F 5°C

B: LIMITED WARRANTY

Perma Pure LLC WARRANTY and DISCLAIMERS

Perma Pure (Seller) warrants that product supplied hereunder shall, at the time of delivery to Buyer, conform to the published specifications of Seller and be free from defects in material and workmanship under normal use and service. Seller's sole obligation and liability under this warranty is limited to the repair or replacement at its factory, at Seller's option, of any such product which proves defective within one year after the date of original shipment from seller's factory (or for a normal usable lifetime if the product is a disposable or expendable item) and is found to be defective in material or workmanship by Seller's inspection.

Buyer agrees that (1) any technical advice, information, suggestions, or recommendations given to Buyer by Seller or any representative of Seller with respect to the product or the suitability or desirability of the product for an particular use or application are based solely on the general knowledge of Seller, are intended for information guidance only, and do not constitute any representation or warranty by Seller that the product shall in fact be suitable or desirable for any particular use or application; (2) Buyer takes sole responsibility for the use and applications to which the product is put and Buyer shall conduct all testing and analysis necessary to validate the use and application to which Buyer puts the product for which Buyer may recommend the use or application of the product by others; and (3) the characteristics, specifications, and/or properties of the product may be affected by the processing, treatment, handling, and/or manufacturing of the product by Buyer or others and Seller takes no responsibility for he nature or consequence of such operations or as to the suitability of the product for the purposes intended to be used by Buyer or others after being subjected to such operations.

SELLER MAKES NO OTHER WARRANTY, EXPRESS OR IMPLIED, OF THE PRODUCT SUPPLIED HEREUNDER, INCLUDING, WITHOUT LIMITATION, IMPLIED WARRANTIES OF MERCHANTABILITY AND FITNESS FOR PARTICULAR PURPOSE, AND ALL SUCH WARRANTIES ARE HEREBY EXPRESSLY EXCLUDED. SELLER SHALL HAVE NO LIABILITY FOR LOSS OF PROFITS, OR SPECIAL, INCIDENTAL, OR CONSEQUENTIAL DAMAGES UNDER ANY CIRCUMSTANCES OR LEGAL THEORY, WHETHER BASED ON NEGLIGENCE, BREACH OF WARRANTY, STRICT LIABILITY, TORT, CONTRACT, OR OTHERWISE. SELLER SHALL IN NO EVENT BE LIABLE IN RESPECT OF THIS ORDER AND OR PRODUCT DELIVERED ON ACCOUNT OF THIS ORDER FOR ANY AMOUNT GREATER THAN THAT PAID TO SELLER ON ACCOUNT OF THIS ORDER.

C: PRINCIPLE OF OPERATION

Thank you for purchasing a Baldwin™-Series eCOOL™ 5000 Digital Thermo-Electric Cooler. The eCOOL™ 5000 Series has numerous features including:

- Remote monitoring and control of heated filter probe, heated sample line, and sample conditioning system.
- eCOOL™ interface software included for monitoring and control over the Internet or a Local Area Network.
- A jumbo 2-line LCD display with multi-colored LED's provides easy local monitoring and control of your sample handling system.
- Alarm notification of over / under temperature, thermocouple failure, and water slip (moisture carryover).
- Alarm relay shuts off the sample pump to protect expensive analyzers from water slip (moisture carryover).
- Eliminates the cost and complexity of separate temperature controllers such as for a heated sample line and filter probe.
- Extra thermocouple inputs and outputs available.
- Operates with 110/120VAC, 220/240VAC, 12VDC, 15VDC, or 24VDC.
- Field friendly, requires virtually no maintenance, and is backed by our 1-year limited warranty.

All Baldwin-Series coolers use thermo-electric elements (Peltiers) to cool the sample gas to the desired dew point temperature. A thermo-electric cooler is best illustrated

as a small heat pump with no moving parts. The Peltiers operate on direct current and may be used for heating or cooling by reversing the direction of current flow. This is achieved by moving heat from one side of the module to the other with current flow and the laws of thermodynamics. A typical single stage Peltier (Figure 1) consists of two ceramic plates with p- and n-type semiconductor material (bismuth telluride) between the

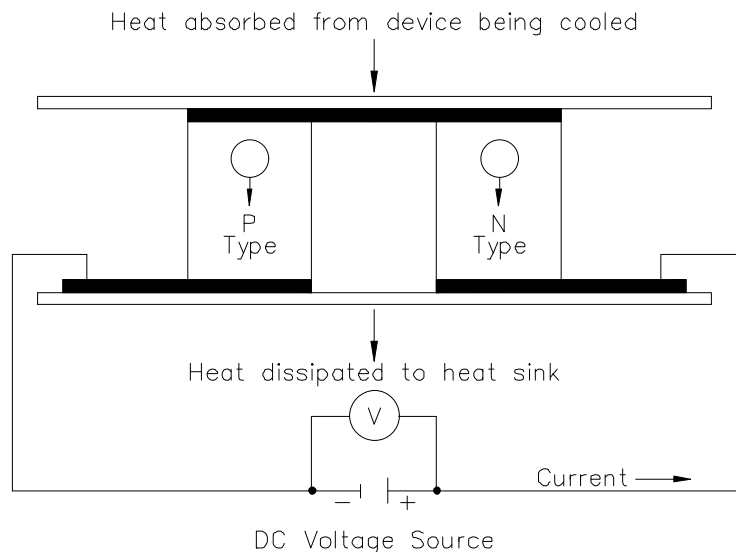

Figure 1: Thermo-electric element (Peltier)

plates. The elements of semiconductor material are connected electrically in series and thermally in parallel.

When a positive DC voltage is applied to the n-type thermo-electric element, electrons pass from the p- to the n-type thermo-electric element and the cold side temperature will decrease as heat is absorbed. The heat absorption (cooling) is proportional to the current and the number of thermo-electric couples. This heat is transferred to the hot side of the Peltier element where it is dissipated into the heat sink and surrounding environment.

Baldwin™-Series Thermo-Electric Coolers remove the moisture from the sample gas by cooling the gas as it passes through a laminar impinger (heat exchanger). A diagram showing the gas flow path through an impinger is shown in the Appendix. The heat exchanger, made of 316L stainless steel, Durinert® (a corrosion-resistant inert coating over 316L stainless steel), PVDF (Kynar®), or glass, is mounted within a thermally insulated heat transfer block bored to receive the heat exchanger without a mechanical lock. This assembly allows the easy removal of any heat exchanger simply by slipping it out of the cooling block by hand. The heat transfer block cools the heat exchanger through the heat pumping action of the peltier element. The heat transfer block is on the cold side of the thermo-electric element and the heat sink is on the hot side of the thermo-electric element. The heat from the heat transfer block is pumped to the heat sink where it is then dissipated into the air by the heat sink fan. See figure 2. The desired temperature is maintained by a closed loop control system, which is implemented through a proportional controller. The controller uses a type K thermocouple in the heat transfer block located very close to the cold side of the peltier element as the input sensor.

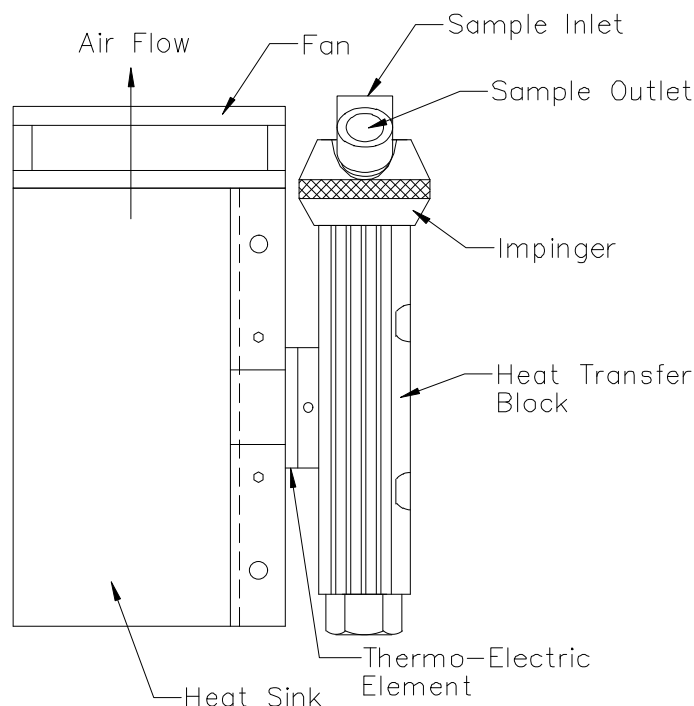

Figure 2: Heat Exchanger, Impinger and Heat Sink Assembly

The sample gas is passed to the thermo-electric cooler via the heated filter sample probe and heated sample line. The thermo-electric cooler lowers the sample dew point to 5 °C (41 °F). As the gas cools and the moisture vapor condenses, the condensate exits the heat exchanger through the bottom drain connection. Particulate matter which passes through the sample cooler is removed by an optional Perma Pure pre-filter, located downstream from the cooler along with an optional water slip sensor. The conditioned sample gas can then be directed to the gas analyzers.

D: INSTALLATION

eCOOL™ 5000 Digital Thermo-Electric Coolers should be installed away from heat sources in a well ventilated area of an instrument rack or enclosure.

Sample tubing connections to the eCOOL™ 5000 Coolers depend on the heat exchanger material of construction. A cooler with stainless steel heat exchangers uses a stainless steel inlet fitting on the first heat exchanger. All other inlets and outlets are Kynar® standard compression type tube fittings with Teflon® ferrules. PVDF (Kynar®) heat exchangers use all Kynar® standard compression type tube fittings with Teflon® ferrules. Perma Pure cannot warrantee against damage to the Peltier elements or heat exchangers if our supplied Kynar® tube fittings are not used.

CAUTION: If using a stainless steel sample line, place 2 inches of Teflon® tubing in between the exchanger inlet fitting and the heated line. This prevents the sample cooler from heat sinking the incoming heated line, which adds undue load to the cooler.

The inlet and outlet tubing of all metal or Kynar® heat exchangers is 1/4" NPT. The operator should use the compression type fittings. The inlet of the first heat exchanger uses a 3/8" tube x 1/4" MNPT, tube connector fitting to mate with most standard 3/8" sample lines.

For eCOOL™ 5000 models that utilize passive/active heat exchangers (i.e., e5300, e5500), the sample pump should be installed after the cooler to protect the pump head from moisture and ensure longer diaphragm life. The sample pump should be installed between the heat exchangers in active/active models (e5400, e5800). This will assist in water removal by pressurizing the downstream heat exchanger. There will be minimal sacrifice in pump diaphragm life since the majority of water will be removed by the first active heat exchanger. It is also acceptable for the sample pump to be installed after active/active coolers.

The condensate drain connections are Kynar® elbows, 3/8" MNPT x 1/4" barbed tube fittings. A Perma Pure peristaltic drain pump is recommended for water removal. This pump uses size 17 tubing.

CAUTION: Do not reduce the size of the condensate tubing since doing so restricts water flow which may result in water slip (moisture carryover) in the sample.

E: START-UP PROCEDURE

Plug in the power cord to a properly grounded main circuit. The LCD should display the actual temperature. The temperature of each channel should fall until it reaches 5°C.

If there are no alarms (an alarm condition consists of water slip detection after the cooler, thermocouple failure, or actual temperature > 10°C), then the LED(s) should turn to an amber color. This indicates that the alarms are cleared and the user can press the reset button to begin operation. Once the reset button is pressed, the LED(s) should turn green indicating that there are no alarms and sample flow can begin. If the sample pump is wired through the relay board alarm contacts and all alarms are cleared, the sample pump will start. The sample pump will stop if any alarms are detected.

Note: Current alarm conditions are displayed on the second line of the LCD.

eCOOL™ 5000 Thermo-Electric Coolers are virtually maintenance free. However, in the event of electrical problems, refer to the *Troubleshooting* section in this manual.

F: LEDs & LCD

Every eCOOL™ 5000 Series Digital Thermo-Electric Cooler has a jumbo 2-line LCD display and 2 LED indicators.

Each of the two LED indicators corresponds to an active heat exchanger and will be colored Green, Amber, or Red:

LED Summary

- GREEN: Status OK, Sampling can begin. Sample pump will run.
- AMBER: Alarm is no longer present. User must press the reset button to acknowledge the alarm and return to normal operation.
Sample pump off.
- RED: Alarm - see message on LCD screen. Sample pump off.

The top line of the LCD screen displays the temperature of each active heat exchanger in degrees Celsius (e.g., 5°C). The scrolling bottom line of the LCD screen displays cooler status, such as alarm messages.

Alarm Summary

- Thermocouple failure
- Channel over-temperature alarm
- Water slip (water detect) alarm

Please refer to the *Troubleshooting* section of this manual if your cooler displays any of the alarms above.

G: BOARDS

Control Board

The control board is the motherboard for the eCOOL system. The control board handles the majority of the functions for the cooler module. It contains the micro processor that controls all of the functional areas of the design, as well as the temperature measurement of the controlled vapor flow as well as the Pulse Width Modulation (PWM) control of the Peltier elements to cool the vapor.

Inputs:

- 4 Thermocouple Inputs (Channel 1, Channel 2, and two Spare)
- 12-24VDC Power Inputs
- 12-24VDC Control Board Power Inputs
- 1 Analog Input

Input/Outputs:

- Relay Board 1 Input/Output
- Relay Board 2 Input/Output
- LAN Card Input/Output
- Accessory Board Input/Output
- Isolator Board Input/Output

Outputs:

- 4 Analog Outputs (scaled 0 to 4.5VDC matching the Thermocouple Inputs)
- Peltier Power Outputs (spade terminals)
- DC Fan Power Output 1
- DC Fan Power Output 2

Power Connections

The board is powered in two locations by a DC power supply rated to handle the current required by the Peltier elements present in the system. The Peltier power is supplied via the E1 and E2 lugs, where E2 is connected to the positive terminal and E1 is connected to ground. The rest of the board is powered by the JP1 power connector. This connector has two terminals on it with number 1 connected to the positive DC voltage coming from the power supply and number 2 connected to ground. The wires that are used to connect to the power supply should be individually routed back to the power supply to minimize the noise created by the peltiers.

Fuses

The fuses are labeled as F1, F2, F3. They are self-resetting fuses. If one of the fuses trips, disconnect all power, identify and correct the problem that caused the

high current draw, and reconnect power. It could take up to 5 minutes for a fuse to self-reset in a power off state.

Main Control Board Overview

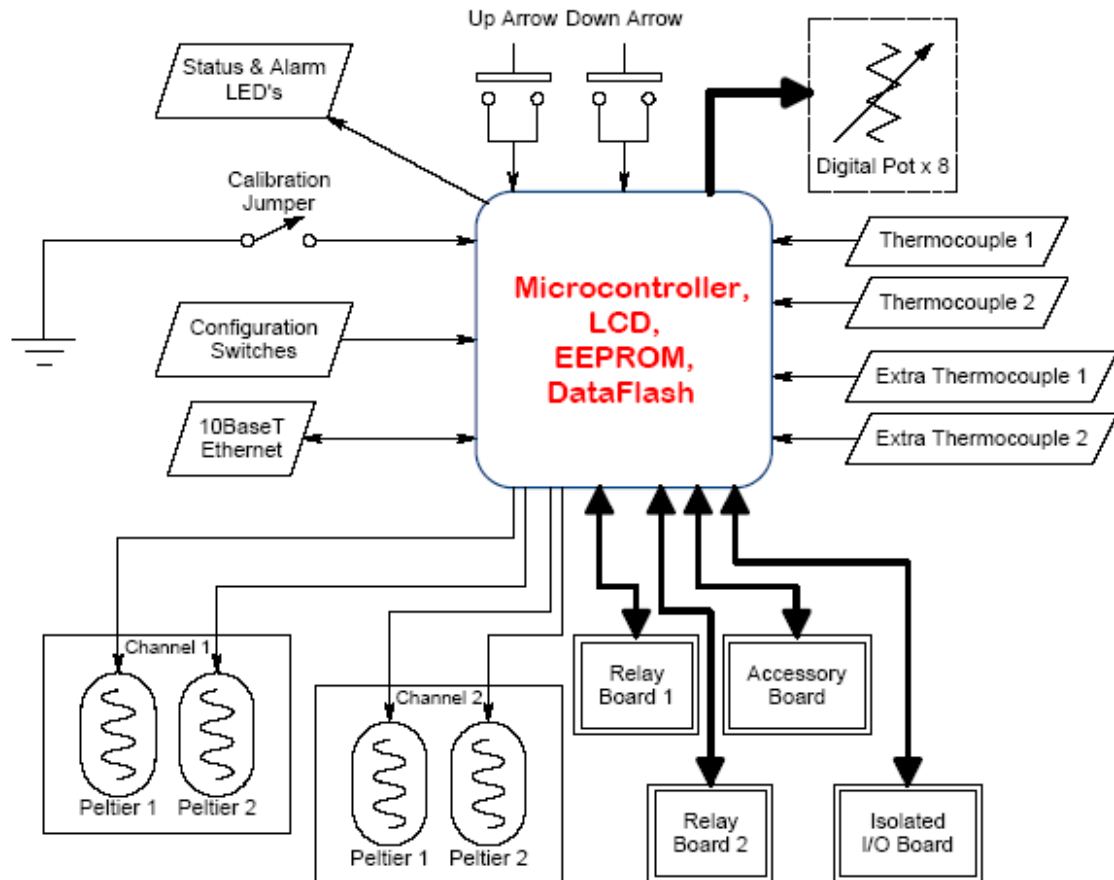

Configuration Switches

The configuration switches identify which components are connected to the system. They are used by the control firmware to determine how the board is going to operate in the system. The switches are read at power-up, or when the external reset switch is activated. The table below identifies the switch positions and their functions.

SW3	Function	OFF	ON
1	Heated Line Control	OFF	ON
2	Probe Control	OFF	ON
3	Peltiers	1 per channel	2 per channel
4	Channels	1	2
5	Peltier Power Share	Full Power	Power Sharing
6	ISO Channels	Inactive	Displayed

SW2	Function	ON	OFF
1	ICE VCC	Enabled	Disabled
2	JTAG ICE ResetN	Enabled	Disabled
3	Calibration	Enabled	Normal Operation
4	Dflash Res	Enabled	Normal Operation
5	Init Clr	Enabled	Normal Operation

Button Control

The buttons are used to control the calibration settings. Follow the bottom line on the display to determine the functions in the different modes. The three combinations that are available are left only, right only, or both. To select the center option on the bottom line of the display, press both buttons together.

Calibration Menus

The calibration mode allows the board to be setup with min and span points as well as all of the other configuration information applicable depending on the configuration switch settings.

Ch1, Ch2, TC1, TC2

Min = 0

Span = 5 degrees C

Max = 8*Span Temp (360°C limit)

The calibration is performed by first calculating the expected settings for the calibration resistors before entering the calibration operation to get a good starting point. Then the 0 point is adjusted to the minimum point in the ADCC (memory chip). The span temperature is then set and the span gain is adjusted to make the span point 1/8 of the entire range for the temperature measurements.

ChX: MIN = xx°C

ChX: SPAN = xx°C

ChX:RDY TMP= xx°C
ChX:SET TMP= xx°C
ChX GAIN=%3u

Probe, Heated Line

Min = 0°C
Span =
Max = 360°C

Calibration is performed by setting the gain of the span circuit to minimal gain then adjusting the 0 point to the minimum reading from the ADCC. The span temperature is used to measure the ADCC value and calculate the step size of the ADCC.

ChX: MIN = xx°C
ChX: SPAN = xx°C
ChX:MIN TMP= xx°C
ChX:MAX TMP= xx°C
ChX:SET TMP= xx°C
ChX: GAIN=%3u

Isolation Channels

Min = 0°C
Max = 25°C

The temperature range for the isolation circuit is 0 to 25°C. The calibration is performed by first calculating a good starting point for the offset and span resistors. Then adjust the 0 point to the minimum point in the ADCC. The last step is to set the input to 25°C and adjust the span gain to achieve the max value in the ADCC.

ChX: MIN = xx°C
ChX: MAX = xx°C
ChX:MIN TMP= xx°C
ChX:MAX TMP= xx°C
ChX:SET TMP= xx°C
ChX: GAIN=%3u

Water Slip (Moisture Carryover) Relay Board

Note: For the following instructions, typical applications run each of the relays in series through the Common and Normally Open (NO) contacts.

A: Computer Status Alarms (External PLC monitoring).

Wire computer status alarms to JP4 & JP2. Wire the Common and Normally Open Contacts in series to a PLC. If an alarm occurs, one or both of these contacts will open.

B: Sample Pump Control – Water slip, over-temperature, thermocouple failure alarms.

Wire the Line (hot) power for the sample pump through terminals through JP3 and JP1. Wire the Common and Normally Open (NO) contacts in series. If an alarm occurs, one or both of these contacts will open.

The sample pump is now in series with the Water Slip (Moisture Carryover) Sensor and the Ready/Slip/power failure relay, which will only allow the sample pump to start if conditions are satisfactory (i.e., no water slip, and safe operating temperature of the sampling system, and no thermocouple failure).

LAN Card

To use the LAN Card, connect the 5 VDC power from the LAN card terminal JP1, to the Power Out terminal on the Control Board terminal JP29 (+5VDC and GND). Connect a ribbon cable between JP15 on the Control Board to JP16 on the LAN Card. Then, connect a Cat 5 Ethernet cable with an RJ45 connector to the LAN Card. The Ethernet cable should connect to a switch or router on a Local Area Network (LAN) to run the TCP/IP executive software or connected to a Modbus server.

Accessory Board

To use the Accessory boards make sure that the shorting jumpers on HDR1 and HDR2 are shorting pins 3-5, 4-6 on both headers. The Accessory board connects to JP23 on the cooler board.

Isolated Output Board

To use the ISO boards make sure that the shorting jumpers on HDR1 and HDR2 are shorting pins 3-5, 4-6 on both headers. The ISO board connects to JP20 on the cooler board.

H: DEFAULT SETPOINTS

eCOOL 5000™ Heat Exchangers:

Setpoint Temperature = 5°C

Run Temperature = 10°C

Cooler must operate below the Run Temperature to avoid the over temperature alarm condition.

Heated Sample Probe:

Setpoint Temperature = 190°C

High Temperature Alarm = 210°C

Low Temperature Alarm = 120°C

Heated Sample Line:

Setpoint Temperature = 190°C

High Temperature Alarm = 210°C

Low Temperature Alarm = 120°C

LAN Card:

Static IP Addressing: 192.168.45.140

DHCP Disabled.

Relay Card:

Relay contacts are in their Normal state (de-energized state) during an alarm condition.

Analog output 0-4.5 VDC equates to 0-10°C corresponding to each thermocouple.

I: “NEW JERSEY” THERMOCOUPLE OPTION

Some air quality management districts (e.g., those in New Jersey and Southern California) require temperature measurement of the gas stream at the outlet of the last heat exchanger on the cooler. Perma Pure offers a 1/32-inch diameter hypodermic-style type K thermocouple that can be inserted into a special heat exchanger (i.e., it has a small port for insertion of the thermocouple) so the actual sample dew point temperature can be measured. This is sometimes referred to as the New Jersey thermocouple outlet temperature option.

If the cooler is run as a single stream, the final heat exchanger will have a New Jersey thermocouple to sense the temperature inside the heat exchanger. A quantity of two (2) NJ thermocouples are required when the cooler is used for dual-stream simultaneous conditioning.

In the Baldwin™-Series eCOOL 5000™, this New Jersey Thermocouple can be connected to one of the extra thermocouple inputs for readout. Alternately, for a 4-20mA output, the optional isolator board should be purchased.

eCOOL™ 5000 Series New Jersey Thermocouple Option

Part No.	Description
3KTC-001	Kit, Thermocouple, NJ Option, Type K, w/Fitting & Sleeve
3KTC-002	Kit, Thermocouple, NJ Option, Type J, w/Fitting & Sleeve
3CCB-026	Circuit Board, eCooler, Isolator Board

J: MAINTENANCE

Note: Please refer to the Spare Parts section of this manual for part numbers and descriptions.

Daily

Verify each channel is running at 5°C (+/- 1.5°C).

LED's should be Green.

Verify cooling fans are running.

Verify that the peristaltic pump is running and water is draining out.

Verify that the sample pump is drawing full flow.

Quarterly

Verify power supply voltage is above 14.5 VDC.

Inspect and clean the EZ-Clean Twist-Apart heat exchangers with de-ionized water. Depending on the composition of the sample stream, heat exchangers may need to be cleaned more often.

Inspect and replace the sample pump diaphragm when needed.

Inspect and replace the peristaltic pump tubing.

Inspect the water slip sensor and verify that there is no corrosion or restrictions to the sensing pins.

Annually

Check and replace the Peltier cooling elements. At room temperature, a Peltier should have a resistance of 5-10 Ohms. Higher resistance signifies the Peltier is stressed and could fail soon.

Using a K-type thermocouple simulator, disconnect each thermocouple and simulate a temperature between 0°C and 10°C. Verify that the readout on the display matches the temperature to within 0.5°C. If it does not, the cooler needs to be recalibrated. Contact Perma Pure for the calibration procedure and assistance.

K: TROUBLESHOOTING

Alarm Message	Symptom	Action(s)
Thermocouple Failure Channel #	Thermocouple is failing or disconnected	Ensure proper connection to TB6 for Channel 1, TB7 for Channel 2. Replace K-type thermocouple.
Water Slip Alarm	Water has slipped passed the thermo-electric cooler and tripped the water slip sensor.	Ensure system loading (gas flow and water %) does not exceed cooler capacity.
		Verify that the cooler last impinger is holding a constant temperature near 5°C. If a dry sensor still trips the alarm, clean the sensor or replace if necessary.
Overtemp Alarm	Cooler channel does not maintain a temperature below 10 degrees C.	Verify that the system loading (gas flow and water %) does not exceed the cooler capacity. Verify that each Peltier element is drawing approximately 6 Amps. Replace the Peltier element if the current draw is low. Calibrate the temperature inputs using a thermocouple simulator.
Probe Overtemp Alarm	Probe temperature has exceeded the Max Set temperature for the probe.	Max temp is set too low. Adjust accordingly. Inlet gas sample temp is too high. Consider installing a cooling spool piece before the probe. Inspect for wiring problem that is not allowing the controller to properly maintain temperature.
Probe Undertemp Alarm	Probe temperature is below the Minimum Set temperature for the probe.	Minimum set temperature is too low. Adjust accordingly. On initial startup, the Heated Probe was initially below the minimum temp, but now is above minimum. Press reset to clear the alarm. The isolated power source for the heater is disconnected or off. The heater is failing, causing the probe to not hold temperature. Inspect for wiring problem that is not allowing the controller to properly maintain temperature.
Heated Line Overtemp Alarm	Heated Line temperature has exceeded the Max Set temperature for the line.	Max set temperature is too low. Adjust accordingly. Inlet gas sample temp is too high. Consider installing a gas cooling spool piece before the probe. Inspect for wiring problem that is not allowing the controller to properly maintain temperature.
Heated line under temperature alarm	Heated Line temperature is below the Minimum Set temperature for the line.	Min set temperature is too low. Adjust accordingly. On initial startup, the Heated Line was initially below the minimum temp, but now is above minimum. Press reset to clear the alarm. The heater is failing causing the Heated Line to not hold temperature. The isolated power source for the heater is disconnected or off. Inspect for wiring problem that is not allowing the controller to properly maintain temperature.

Problem	Check	Action(s)
No LCD or LED(s) and no fan.	AC power input. DC 3A fuse (F1) on control board. AC 15A fuse on power supply. Check for +15VDC at P1 & P11 of control board.	Ensure that AC power is connected. Replace fuse as necessary. Replace fuse as necessary. If low reading, remove wires from P1 & P11, measure at power supply and replace supply if voltage still is low.
Heat exchanger remains at ambient temperature.	Peltier element current draw. (Should be above 6 amps.)	Replace Peltier element.
Heat exchanger frozen and cooler indicates ambient temperature.	Thermocouple placement in heat exchanger block. Peltier current draw (>6A) for both elements on that channel.	Ensure proper placement. Replace Peltier element.
Impinger does not reach set temperature, but is below ready temperature.	System loading. Calibration and set temperature adjustment.	Ensure system loading is not exceeding cooler capacity. Adjust as necessary.
Heat exchanger temperature cycles up and down.	Peltier element connections on control board. Ferrite beads on thermocouples going into terminal TB1 & TB2	Ensure a firm connection on flag connectors on control board. Ensure system loading is not exceeding cooler capacity. Wrap a Ferrite bead around thermocouple wires.
Water carryover in system.	Heat exchanger temperature. (Should be below 6°C.)	Ensure system loading is not exceeding cooler capacity.
Pump does not start. LCD(s) are green.	Pump electrical connections.	Ensure proper connections. Replace relay board.

For further service assistance, contact:

Perma Pure LLC
P.O. Box 2105
8 Executive Drive (08755)
Toms River, NJ 08754
Tel: 800-337-3762 (toll free U.S.)
Tel: 732-244-0010
Fax: 732-244-8140
Email: info@permapure.com
or your local representative

L: SPARE PARTS: eCOOL™ 5000

Model e5300

Part No.	Description
3CCB-023	Circuit Board, eCool® 5000, Relay Board
2FAN-004	Fan: Muffin, 4" x 1 1/2", 12 VDC
3CXD-023	Heat Exchanger, SS, EZ-Clean™ Twist-Apart, 5", Durinert® Coated
3CXG-005	Heat Exchanger: 5" Glass, threaded w/ fittings
3CXK-001	Heat Exchanger: 5" Kynar
3CXS-023	Heat Exchanger, SS, Twist-Apart, 5"
3KPE-004	Peltier Element Kit, 40 mm
1PSD-013	Power Supply: 100 W, 12 VDC
3CCB-022	Circuit Board, eCOOL, Control Board
3CCB-024	Circuit Board, eCOOL, LAN Card
3CCB-025	Circuit Board, eCOOL, Accessory Board
3CCB-026	Circuit Board, eCOOL, Isolator Board
1TTC-003	Thermocouple, Temperature, Control, Type K 36"

Model e5400

Part No.	Description
3CCB-023	Circuit Board, eCool® 5000, Relay Board
2FAN-004	Fan: Muffin, 4" x 1 1/2", 12 VDC
3CXD-023	Heat Exchanger, SS, EZ-Clean™ Twist-Apart, 5", Durinert® Coated
3CXG-005	Heat Exchanger: 5" Glass, threaded w/ fittings
3CXK-001	Heat Exchanger: 5" Kynar
3CXS-023	Heat Exchanger, SS, Twist-Apart, 5"
3KPE-004	Peltier Element Kit, 40 mm
1PSD-027	Power Supply: 240 W, 15 VDC
3CCB-022	Circuit Board, eCOOL, Control Board
3CCB-024	Circuit Board, eCOOL, LAN Card
3CCB-025	Circuit Board, eCOOL, Accessory Board
3CCB-026	Circuit Board, eCOOL, Isolator Board
1TTC-003	Thermocouple, Temperature, Control, Type K 36"

Model e5500

Part No.	Description
3CCB-022	Circuit Board, eCool® 5000, Control Board
2FAN-005	Fan: Muffin, 4" x 1", 12 VDC
2FAN-007	Fan: Muffin, 6" x 1 1/2", 12 VDC
3CXD-022	Heat Exchanger, SS, EZ-Clean™ Twist-Apart, 10", Durinert® Coated
3CXG-006	Heat Exchanger: 10" Glass, threaded w/ fittings
3CXK-003	Heat Exchanger: 10" Kynar
3CXS-022	Heat Exchanger, SS, Twist-Apart, 10"
3KPE-004	Peltier Element Kit, 40 mm
1PSD-027	Power Supply, 240Watts, 15VDC
3CCB-023	Circuit Board, eCOOL, Relay Board
3CCB-024	Circuit Board, eCOOL, LAN Card
3CCB-025	Circuit Board, eCOOL, Accessory Board
3CCB-026	Circuit Board, eCOOL, Isolator Board
1TTC-001	Thermocouple: Temperature, Control, Type K, 24"

Model e5500XP

Part No.	Description
3CCB-022	Circuit Board, eCool [®] 5000, Control Board
2FAN-005	Fan: Muffin, 4" x 1", 12 VDC
2FAN-007	Fan: Muffin, 6" x 1½", 12 VDC
3CXD-022	Heat Exchanger, SS, EZ-Clean™ Twist-Apart, 10", Durinert [®] Coated
3CXG-006	Heat Exchanger: 10" Glass, threaded w/ fittings
3CXK-003	Heat Exchanger: 10" Kynar
3CXS-022	Heat Exchanger, SS, Twist-Apart, 10"
3KPE-004	Peltier Element Kit, 40 mm
1PSD-028	Power Supply, 300W, 24VDC, 12A, Explosion Proof, Class 1, Div 2
3CCB-023	Circuit Board, eCOOL, Relay Board
3CCB-024	Circuit Board, eCOOL, LAN Card
3CCB-025	Circuit Board, eCOOL, Accessory Board
3CCB-026	Circuit Board, eCOOL, Isolator Board
1TTC-001	Thermocouple: Temperature, Control, Type K, 24"

Model e5800

Part No.	Description
3CCB-022	Circuit Board, eCool [®] 5000, Control Board
2FAN-005	Fan: Muffin, 4" x 1", 12 VDC
2FAN-007	Fan: Muffin, 6" x 1½", 12 VDC
3CXD-022	Heat Exchanger, SS, EZ-Clean™ Twist-Apart, 10", Durinert [®] Coated
3CXG-006	Heat Exchanger: 10" Glass, threaded w/ fittings
3CXK-003	Heat Exchanger: 10" Kynar
3CXS-022	Heat Exchanger, SS, Twist-Apart, 10"
3KPE-004	Peltier Element Kit, 40 mm
1PSD-009	Power Supply: 500W, 15VDC
3CCB-023	Circuit Board, eCOOL, Relay Board
3CCB-024	Circuit Board, eCOOL, LAN Card
3CCB-025	Circuit Board, eCOOL, Accessory Board
3CCB-026	Circuit Board, eCOOL, Isolator Board
1TTC-001	Thermocouple: Temperature, Control, Type K, 24"

Model e5800XP

Part No.	Description
3CCB-022	Circuit Board, eCool [®] 5000, Control Board
2FAN-005	Fan: Muffin, 4" x 1", 12 VDC
2FAN-007	Fan: Muffin, 6" x 1½", 12 VDC
3CXD-022	Heat Exchanger, SS, EZ-Clean™ Twist-Apart, 10", Durinert [®] Coated
3CXG-006	Heat Exchanger: 10" Glass, threaded w/ fittings
3CXK-003	Heat Exchanger: 10" Kynar
3CXS-022	Heat Exchanger, SS, Twist-Apart, 10"
3KPE-004	Peltier Element Kit, 40 mm
1PSD-028	Power Supply, 300W, 24VDC, 12A, Explosion Proof, Class 1, Div 2
3CCB-023	Circuit Board, eCOOL, Relay Board
3CCB-024	Circuit Board, eCOOL, LAN Card
3CCB-025	Circuit Board, eCOOL, Accessory Board
3CCB-026	Circuit Board, eCOOL, Isolator Board
1TTC-001	Thermocouple: Temperature, Control, Type K, 24"

Model e5900

Part No.	Description
3CCB-022	Circuit Board, eCool [®] 5000, Control Board
2FAN-005	Fan: Muffin, 4" x 1", 12 VDC
2FAN-007	Fan: Muffin, 6" x 1½", 12 VDC
3CXD-022	Heat Exchanger, SS, EZ-Clean™ Twist-Apart, 10", Durinert [®] Coated
3CXG-006	Heat Exchanger: 10" Glass, threaded w/ fittings
3CXK-003	Heat Exchanger: 10" Kynar
3CXS-022	Heat Exchanger, SS, Twist-Apart, 10"
3KPE-004	Peltier Element Kit, 40 mm
1PSD-009	Power Supply: 500W, 15VDC
3CCB-023	Circuit Board, eCOOL, Relay Board
3CCB-024	Circuit Board, eCOOL, LAN Card
3CCB-025	Circuit Board, eCOOL, Accessory Board
3CCB-026	Circuit Board, eCOOL, Isolator Board
1TTC-001	Thermocouple: Temperature, Control, Type K, 24"

Model e5900XP

Part No.	Description
3CCB-022	Circuit Board, eCool [®] 5000, Control Board
2FAN-005	Fan: Muffin, 4" x 1", 12 VDC
2FAN-007	Fan: Muffin, 6" x 1½", 12 VDC
3CXD-022	Heat Exchanger, SS, EZ-Clean™ Twist-Apart, 10", Durinert [®] Coated
3CXG-006	Heat Exchanger: 10" Glass, threaded w/ fittings
3CXK-003	Heat Exchanger: 10" Kynar
3CXS-022	Heat Exchanger, SS, Twist-Apart, 10"
3KPE-004	Peltier Element Kit, 40 mm
1PSD-028	Power Supply, 300W, 24VDC, 12A, Explosion Proof, Class 1, Div 2
3CCB-023	Circuit Board, eCOOL, Relay Board
3CCB-024	Circuit Board, eCOOL, LAN Card
3CCB-025	Circuit Board, eCOOL, Accessory Board
3CCB-026	Circuit Board, eCOOL, Isolator Board
1TTC-001	Thermocouple: Temperature, Control, Type K, 24"

APPENDIX: eCOOL 5000™

E Cool LAN Card Setup and Configuration

Setup:

1. Start a Hyperterminal session or similar terminal emulation software and configure it to operate at 57600,8 data bits, No Parity, and 1 Stop Bit.
2. Disconnect power from the E Cool cooler card
3. Connect the E Cool LAN card that is to be configured with the following connectors:
 - a. JP15 - 10 pin connector to DB9 adapter to serial cable connected to PC.
 - b. JP16 - 10 pin ribbon cable to JP15 on the E Cool cooler board
 - c. P1 - Connected to Ethernet Cable
 - d. JP1 - Connected to +5V power and GND coming from the E Cool cooler board JP29.
4. Apply power to the E Cool cooler card
5. Press the reset button on the E Cool LAN card (SW1)
 - a. The Hyperterminal window should now have configuration information from the card.
 - b. The last line should show "ATMEL ok."
6. Add a shorting jumper to JP12 to allow EEPROM configuration

Configuration via terminal program:

1. Type **bootinfo** to get a list of the current settings for the card
2. Choose to Enable/Disable DHCP
If DHCP is enable, the DHCP server can be setup to assign a specific IP address to the unique MAC address for the LAN card. The address is found printed on a label on the card. The MAC address can also be obtained by holding down SW5 on the main control board an monitoring the LCD display. By assigning the address in the DHCP server the card will get the same address each time it is powered up.
 - a. To Enable DHCP enter **dhcp enable**
 - b. To Disable DHCP enter **dhcp disable** (factory default)
3. If DHCP is disabled: (factory default values shown)
 - a. Assign a static IP address
 - ip 192.168.45.145
 - b. Assign a DNSserver (if required; no value factory set)
 - dns xxx.xxx.xxx.xxx
 - c. Assign a default gateway
 - gw 192.168.45.100
 - d. Assign a subnet mask
 - subnetmask 255.255.255.0
4. Press the reset button on the E Cool LAN card (SW1)
Verify that the card gets either gets an IP address from the DHCP server or contains the statically assigned IP address by monitoring the terminal program.
5. *Remove* the shorting jumper from JP12
6. Power down the E Cool controller card