

Micro-GASS™ Model UG-1212 Gas Analysis Sampling System

User Manual



PERMA PURE LLC

8 EXECUTIVE DRIVE

TOMS RIVER, NEW JERSEY 08755

732.244.0010 800.337.3762 FAX 732.244.8140 INFO@PERMAPURE.COM

A HALMA COMPANY

WWW.PERMAPURE.COM

TABLE OF CONTENTS

Warranty and Disclaimer:	5
Warnings	7
Trademarks	7
1.0 System and Component Description	9
MicroGASS™ System.....	9
Particulate Filter.....	9
Nafion® Membrane Dryer	9
Sample Gas Pump	10
2.0 Control System	10
System Power.....	10
Pump Power	10
Filter Temperature Control	10
Dryer Temperature Control.....	10
Flow Control	10
3.0 Installation	11
Mounting.....	11
Electrical Connections	11
Electrical conduit connection -	11
Electrical conductor connections -	11
Heated Line connection –	11
Mechanical Connections.....	12
Wet Sample Gas Inlet -	12
Calibration Gas Inlet -	12
Dry Sample Gas Outlet -	12
Dry Sample Gas Return -	13
Exhaust -	13
4.0 Operation	13
Start-Up/Shutdown Procedures.....	13
Start-Up.....	13
Shutdown	14
5.0 Maintenance and Repair	14
Periodic checks	14
Sample Gas Flow Rate.....	14
Sample Gas Filter.....	14
Coalescing Filter Element Replacement.....	14
Dryer Element Replacement	15
Sample Pump Replacement	16
6.0 Appendices	17
Appendix A – Specifications	17
Appendix B - Micro-GASS System Spare/Repair Parts.....	19
Appendix C – CAL 3300 Temperature Controller Configuration.....	21
Appendix D – Drawings	23
Cutsheet Drawing.....	25
Electrical Diagram	27
Flow Diagram	29

Warranty and Disclaimer:

Seller warrants that product supplied hereunder shall, at the time of delivery to Buyer, conform to the published specifications of Seller and be free from defects in material and workmanship under normal use and service. Seller's sole obligation and liability under this warranty is limited to the repair or replacement at its factory, at Seller's option, of any such product which proves defective within one year after the date of original shipment from seller's factory (or for a normal usable lifetime if the product is a disposable or expendable item) and is found to be defective in material or workmanship by Seller's inspection.

Buyer agrees that (1) any technical advice, information, suggestions, or recommendations given to Buyer by Seller or any representative of Seller with respect to the product or the suitability or desirability of the product for any particular use or application are based solely on the general knowledge of Seller, are intended for information guidance only, and do not constitute any representation or warranty by Seller that the product shall in fact be suitable or desirable for any particular use or application; (2) Buyer takes sole responsibility for the use and applications to which the product is put and Buyer shall conduct all testing and analysis necessary to validate the use and application to which Buyer puts the product for which Buyer may recommend the use or application of the product by others; and (3) the characteristics, specifications, and/or properties of the product may be affected by the processing, treatment, handling, and/or manufacturing of the product by Buyer or others and Seller takes no responsibility for the nature or consequence of such operations or as to the suitability of the product for the purposes intended to be used by Buyer or others after being subjected to such operations.

SELLER MAKES NO OTHER WARRANTY, EXPRESS OR IMPLIED, OF THE PRODUCT SUPPLIED HEREUNDER, INCLUDING, WITHOUT LIMITATIONS, IMPLIED WARRANTIES OF MERCHANTABILITY AND FITNESS FOR PARTICULAR PURPOSE, AND ALL SUCH WARRANTIES ARE HEREBY EXPRESSLY EXCLUDED. SELLER SHALL HAVE NO LIABILITY FOR LOSS OF PROFITS, OR SPECIAL, INCIDENTAL, OR CONSEQUENTIAL DAMAGES UNDER ANY CIRCUMSTANCES OR LEGAL THEORY, WHETHER BASED ON NEGLIGENCE, BREACH OF WARRANTY, STRICT LIABILITY, TORT, CONTRACT, OR OTHERWISE. SELLER SHALL IN NO EVENT BE LIABLE IN RESPECT OF THIS ORDER AND OR PRODUCT DELIVERED ON ACCOUNT OF THIS ORDER FOR ANY AMOUNT GREATER THAN THAT PAID TO SELLER ON ACCOUNT OF THIS ORDER.

WARNING

Thank you for purchasing sample gas conditioning equipment from Perma Pure LLC. We want your new sample gas conditioning equipment to operate safely. Anyone who installs or uses this equipment should read this publication before installing or operating this equipment.

To minimize the risk of potential safety problems, you should follow all applicable local and national codes that regulate the installation and operation of your equipment. These codes vary from area to area and usually change with time. It is your responsibility to determine which codes should be followed and to verify the equipment, installation and operation is in compliance with the latest revision of these codes.

At a minimum, you should follow all applicable sections of the National Fire Code, National Electrical Code, and the codes of the National Electrical Manufacturer's Association (NEMA). There may be local regulatory or government offices that can also help determine which codes and standards are necessary for safe installation and operation.

Equipment damage or serious personal injury can result from the failure to follow all applicable codes and standards. We do not guarantee the products described in this publication are suitable for your particular application, nor do we assume any responsibility for your system design, installation or operation. This product should not be operated in any manner that is inconsistent with its intended use.

If you have any questions concerning the installation or operation of this equipment, or you need additional information, please call us at 1-800-337-3762.

This publication is based on information that was available at the time it was printed. At Perma Pure we constantly strive to improve our products and services, so we reserve the right to make changes to the products and/or publications at any time without notice and without any obligation. This publication may also discuss features that may not be available in certain revisions of the product.

Trademarks

Nafion[®], Viton[®] and Teflon[®] are registered trademarks of EI DuPont de Nemours
Copyright 1996-2010, Perma Pure LLC All Rights Reserved

1.0 System and Component Description

MicroGASS™ System

The Perma Pure MicroGASS™ system prepares gas samples for analysis by electrochemical sensor (ECS) and other analyzers when the sample is too humid for analysis but not condensing at ambient temperature. ECS analyzers suffer reliability problems when the sample is either too wet or too dry. MicroGASS systems reduce sample humidity to the ideal range for ECS (typically 20-80%RH), while also removing dust or dirt particles. MicroGASS sampling systems offer full corrosion resistance and very high selectivity to water vapor, so complex samples can be processed without loss of analyte gases. Nafion® dryer technology is the driving force behind this system. Operating as a self-contained unit, the MicroGASS incorporates a built-in pump to draw the sample gas through a filter and MD-Series™ Nafion® dryer. Clean sample gas then flows to the sensor where the measurement is made. After exhausting from the analyzer and returning to the system, the gas passes through a needle valve and expands, causing a reduction in vapor pressure. It then re-enters the dryer to be used as a purge gas. Because the purge gas is generated from the sample gas exhaust stream of the sensor, the MicroGASS gas conditioning process is self-regenerating. No maintenance, other than regular replacement of the particulate filter element, is required. System power is supplied by a standard 115 or 220 VAC circuit

Particulate Filter

The particulate filter's function is to remove small amounts of particulate matter from the sample stream that could, over time, contaminate the system and degrade performance of the system. High levels of particulate matter should be removed by alternate means upstream of the MicroGASS system. This is typically accomplished with a heated filter at the point of sample gas extraction.

Nafion® Membrane Dryer

The dryer consists of a Nafion® membrane tube housed inside a tubular shell. The sample inlet portion of the dryer is heated to provide rapid removal of the water and to prevent condensation. Nafion transfers water vapor with a higher efficiency at elevated temperatures yet will allow for drying to lower water concentration at lower temperatures. For this reason, only the inlet portion is heated. As wet sample gas enters the Nafion® tube, water vapor is transferred through the membrane and carried off by a counter-current gas flow at a reduced pressure. The driving force for this process is the difference in partial vapor pressure of water between the sample and purge gas flows. In the MicroGASS system, the dried sample gas flow is returned from the gas sensor or analyzer, expanded to about 1/2 atm pressure and then passed through the shell portion of the dryer as the purge gas. While all of this may be confusing and sounds like black magic, it's not. The sample gas leaves the system with the same water content that it entered with. What is important to note is that the majority of the water vapor is essentially short-circuited inside the dryer. The sample gas flow from the system to the sensor and back is the only section of the plumbing where the humidity of the sample gas is low and condensation cannot occur. Some of the water vapor will condense as the sample gas exits the system

Sample Gas Pump

The sample gas pump draws sample gas from the source, through the dryer and analyzer. By generating a vacuum in the process, it serves to create the proper conditions for the sample gas to be used as the purge gas. The pump has a capacity up to 1 lpm and is made from materials highly resistant to chemical attack.

2.0 Control System

System Power

The system power switch controls power to the temperature controller, filter heaters, and dryer heaters. System power is on a 2 Amp fuse, located on the control panel. The heated-line connector is directly connected to the AC power input terminal block. As a result, the power switch does not interrupt power to this circuit. There is a 10A inline fuse in this circuit.

Pump Power

Pump power is enabled by the temperature controller when the system reaches the operating temperature setpoint. With the switch in the ON position, the pump will automatically turn on when the dryer temperature reaches setpoint. This allows the pump to draw the wet sample into the system only when the system is ready.

Filter Temperature Control

The particulate filter is thermostatically controlled via a solid state relay and pad style heaters that are attached to the aluminum housing that surrounds the filter. The setpoint is fixed at 100C and does not require adjustment.

Dryer Temperature Control

The Nafion® membrane dryer temperature is monitored and controlled by an electronic temperature controller via a solid state relay and pad style heaters. A type K thermocouple is used to sense the temperature. The setpoint temperature range is from 35°C to 65°C.

Flow Control – Sample gas flow is measured and controlled by a float type rotameter after it returns to the MicroGASS. The flow meter should be adjusted to provide a flow of between 0.5 to 1.0 lpm for optimal performance of the system.

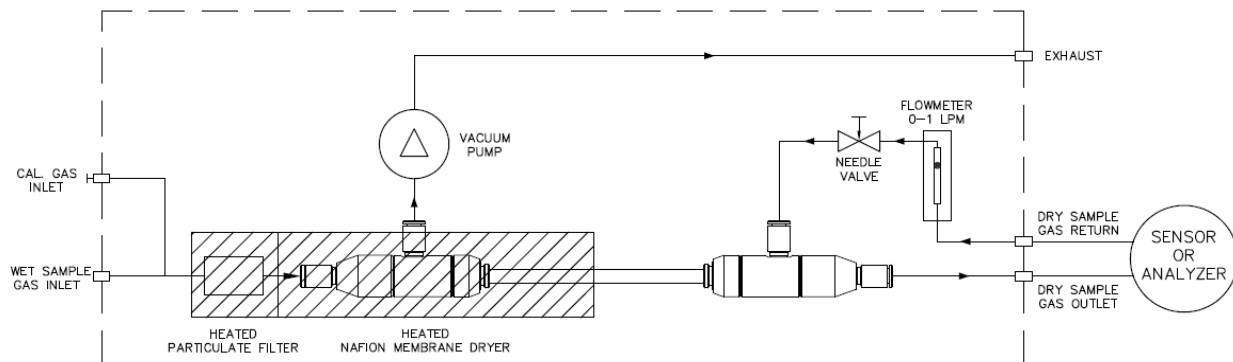

Figure 1- Flow Diagram

3.0 Installation

Mounting

The Micro-GASS enclosure is rated NEMA-4 however, the system is intended for indoor installation. When choosing a mounting location, choose a location that avoids exposure to direct sunlight as it may raise the internal temperature beyond the system operating limits. The system should also not be subjected to extremely cold temperatures. Wall mounting of the system is required for proper operation of the flow meter. A set of four mounting feet are supplied for mounting the system on 12.4" centers.

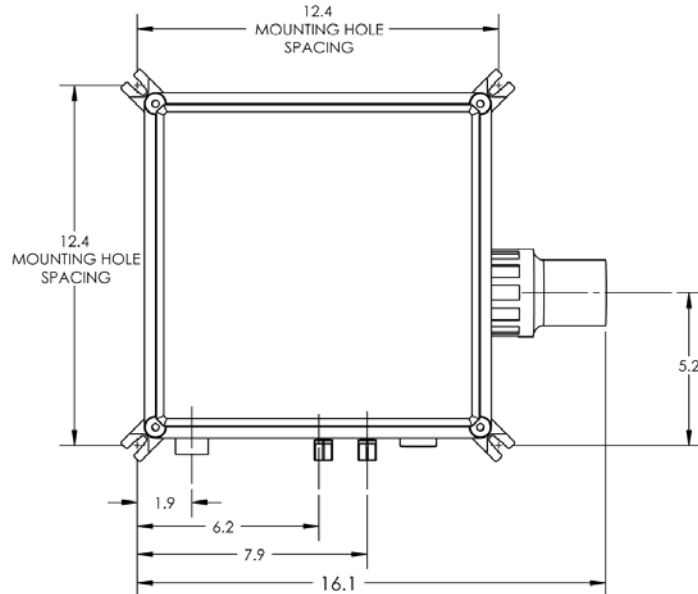

Figure 2 – Mounting Dimensions

Electrical Connections

Confirm the operating voltage on the system nameplate before connecting power.

Electrical conduit connection - The system is supplied via the 1/2" electrical hub that can be used to attach sealtite™ flexible conduit or rigid metal or plastic conduit.

Electrical conductor connections - Made at a terminal block located inside the enclosure near the conduit hub. The MicroGASS system is factory configured for either 115 or 220VAC operation.

Heated Line connection – A three pole Molex style inline connector is provided to supply 10A fused power to a heated line if desired. Voltage will be present at this connector whenever power is connected to the system. For this reason, it is recommended that the system power be supplied via a fused disconnect switch.

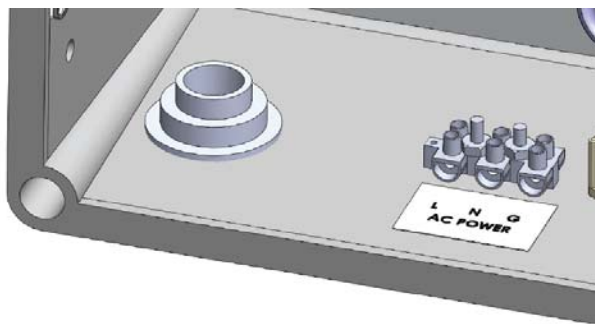

Figure 3 – Electrical Connections

Mechanical Connections

All connections to the MicroGASS system are intended to be made with Teflon or other suitable plastic tubing

Wet Sample Gas Inlet - Compression fitting for ¼" OD Tubing. To be connected to the sample gas source via a heat traced line to prevent condensation of the sample gas. Once the heated sample line is installed, the heated line inlet fitting can be shrunk into place permanently.

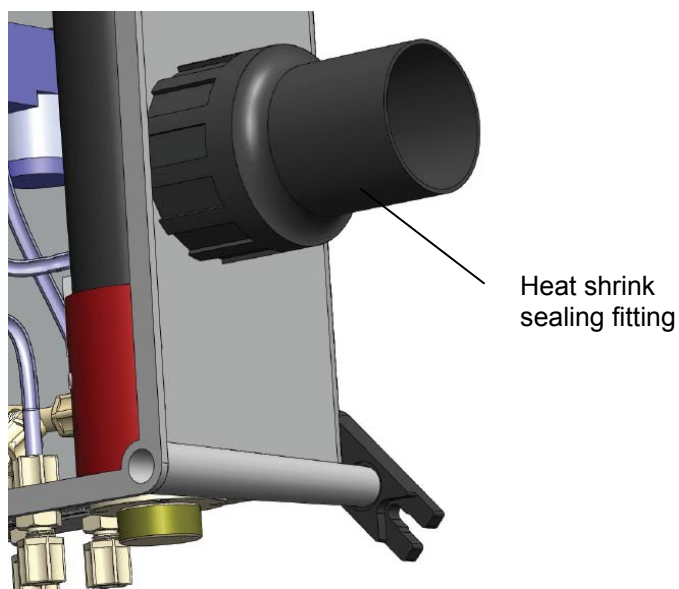

Figure 4 – Heated Line Connection

Calibration Gas Inlet - Compression fitting for ¼" OD Tubing. To be connected to the sample calibration gas source. Do not exceed 30 psi. Port must be capped when not in use

Dry Sample Gas Outlet - Compression fitting for ¼" OD Tubing. To be connected to analyzer's inlet port

Dry Sample Gas Return - Compression fitting for ¼" OD Tubing. To be connected to analyzer's outlet port

Exhaust - Compression fitting for ¼" OD Tubing. This port may be left open to atmosphere if the gas being sample is non-toxic and non-corrosive or piped to an outside location or vent/drain. If the port is connected to a remote drain or vent, do not exceed 10 ft of ¼" tubing or 30 ft of 3/8" tubing to avoid restriction of the flow.

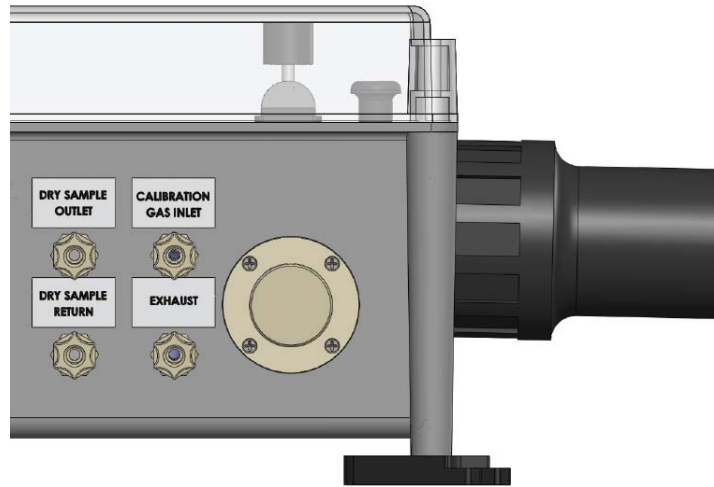

Figure 5 - Mechanical Connection

4.0 Operation

Start-Up/Shutdown Procedures

Start-Up

1. Once all sample, purge, and electrical connections have been made, the system is ready for operation. Start with the sample flow meter closed and system and pump power switches in the "OFF" position.
2. Apply power to the system. This supplies power to the heated line if the heated line power connector included with the MicroGASS system was used. If the heated line power was supplied otherwise, turn on power to the heated line.
3. Allow adequate time for the heated line to come up to temperature.
4. Turn on the "System Power" switch. This supplies power to the filter heaters and the dryer heater temperature controller. After a short amount of time, the temperature controller will display the dryer temperature.
5. Adjust the system (dryer) set-point temperature to 35°C, or 10°C above the maximum anticipated dew point temperature, whichever is higher. Refer to the Appendix for the temperature controller instructions.

6. Switch "Pump Power" switch to the "ON" position. To prevent wet sample gas from entering the unheated dryer, the sample pump is powered via the temperature controller. A relay in the temperature controller remains open until the system temperature comes to within 5°C of the setpoint at which point, the pump will turn on. The system will require less than 5 minutes before the operating temperature is reached but please allow about 15 minutes for the balance of the system to come to a stable temperature.
7. Slowly open the valve on the flow meter by turning counterclockwise, adjust the flow to the desired rate (0.5 to 1 lpm). Lower flows result in dryer gas samples. Samples with a dew point of greater than 35°C should be run at no more than 0.5 lpm.

Shutdown

1. To prevent wet gases from condensing in the Nafion dryer, follow this procedure to purge wet sample gas from the system before shutting down.
2. With system and pump power switches both in the "ON" position remove the filter cap from the bottom of the enclosure (Check condition of the filter element.)
3. Allow the pump to run for about two minutes.
4. Turn the power switches to the "OFF" position and replace the filter cap.

5.0 Maintenance and Repair

Periodic checks

Sample Gas Flow Rate

Check daily for proper flow rate in the range of 0.5 to 1.0 lpm

Sample Gas Filter

Check frequently for excessive buildup of particles on the outside of the element or if a noticeable loss of gas flow is detected and can not be adjusted with the flow meter needle valve.

Coalescing Filter Element Replacement

The filter element should be checked regularly to ensure that the element is in good condition. If the filter is dirty or causing a flow restriction, replace the filter element.

1. Remove the filter cap and element.
2. Inspect the o-ring for damage and replace if necessary.
3. Fit new filter element to raised portion of the filter cap and replace filter cap.
4. Tighten until snug, **do not overtighten**.

Dryer Element Replacement

Under the operating conditions specified, the Nafion® dryer element should last for several years. However, if the element becomes wet, clogged, or dirty it may require replacement.

Disconnect the system power source before continuing

1. Remove four (4) screws from filter housing flange.



Remove these screws

2. Open cover and lift control panel to gain access to the system components.
3. Disconnect the tube running from the pump to the dryer exhaust at the dryer end.

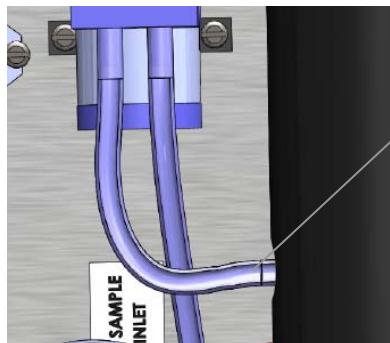

Remove tube at this location

4. Using a 3/32" Allen wrench, remove the dryer exhaust fitting from the dryer

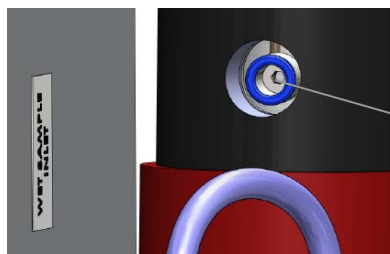

3/32" Allen socket for fitting removal

5. Disconnect both tubes from the opposite end of the dryer.
6. Using a 3/32" Allen wrench, remove the side fitting at the opposite end of the dryer to allow it to slip through the heated section.

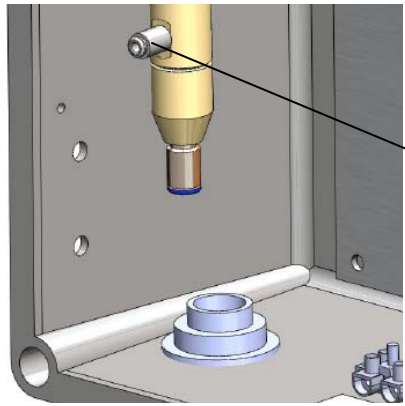

Remove this fitting

7. Cut the wire tie that holds the dryer in a loop.

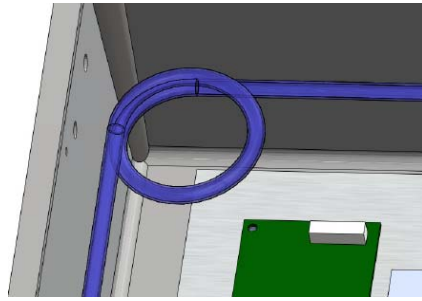

8. Pull gently on the filter housing flange and slip the entire filter/dryer assembly out of the system.
9. Refer to the MD dryer element replacement instructions and replace the dryer element.

Sample Pump Replacement

Under the operating conditions specified, the sample should last for more than a year under typical conditions.

Remove the four mounting screws, disconnect the electrical connector and tubing from the pump. Remove pump.

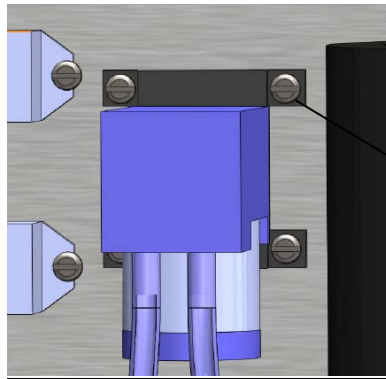

Remove these four screws

6.0 Appendices

Appendix A – Specifications

SAMPLE GAS INLET TEMPERATURE		65°C (150°F) MAX.
SAMPLE GAS PRESSURE/VACUUM		30 PSIG MAX.
		-1 in. Hg MIN.
SAMPLE FLOW RATE		0.5 to 1.0 LPM
ELECTRICAL REQUIREMENTS (Not including heated line power of 10A max.)		115VAC, 1.2A
		220VAC, 0.6A
GAS INLET/OUTLET FITTINGS		¼" TUBE COMPRESSION FITTINGS
OPERATING ENVIRONMENT		10°C to 40°C AMBIENT, 0 to 95% R.H.
NAFION TUBE INNER DIAMETER		0.060" +/- 10%
SAMPLE GAS INLET HUMIDITY (DEW POINT, °C)		55°C (130°F) MAX.
SAMPLE GAS INLET HUMIDITY (% BY VOL.)		15% MAX.
SOLUBLE GAS REMOVAL RATES	GAS	% LOSS
	NO	0
	NO2	0
	SO2	0
	CO	0
	CO2	0
	H2S	0
	HCl	0

Appendix B - Micro-GASS System Spare/Repair Parts

<u>Part #</u>	<u>Description</u>
UG-0000-02-01	Filter cap/element holder
100018	O-Ring, Viton® for filter cap
MD-070-24E-F	Nafion® dryer element only, 0.070" O.D., 24" length
MD-070-24F-R	Nafion® dryer assembly, 0.070" O.D., 24" length element
UG-FE	Micro-GASS filter element (package of 5 elements)
UG-1212-PUMP	Pump, 24VDC
UG-FM	Flow meter, sample gas (0-1.2 L/min)
100396	Solid state relay, dryer or filter
101212	Power supply, 24VDC
100403	Temperature Controller

Appendix C – CAL 3300 Temperature Controller Configuration

- 1 *For all Micro-GASS systems with the CAL3300 Temperature controller, perform the following setup procedures.*
 - a **Power Up** - Apply power to the system and wait for the controller to perform its self test routine. The display will then be alternately flashing “nonE” and “inPt”.
 - b **Input sensor type** - Press and hold ★ key. Press ▲ key repeatedly to select the “tc K” option for K type thermocouple. Release both keys.
 - c **Input unit type** - Press the ▲ key once. The display will then be alternately flashing “unit” and “nonE”. Press and hold the ★ key. Press ▲ key repeatedly to select the “°C” unit. Release both keys.
 - d **Input setpoint 1 type** - Press the ▲ key once. The display will then be alternately flashing “SP1.d” and “nonE”. Press and hold the ★ key. Press ▲ key once to select the output device “SSd”. Release both keys.
 - e **Input the maximum temperature setpoint** - Press and hold the ▼ key until “LEVL” appears. Press and hold the ★ key. Press the ▼ key to move to level 2. Release the two keys. Press and hold the ▲ key until “hi.SC” appears. Press and hold the ★ key. Press the ▼ key until “65” appears. Release the two keys.
 - f **Input the minimum temperature setpoint** Press the ▲ key once. “Lo.SC” appears. Press and hold the ★ key. Press the ▲ key until “45” appears. Release the two keys.
- 2 *Configure the low temperature alarm.*
 - a **Configure SP2 relay as alarm** - Press and hold ▲ and ▼ keys simultaneously for 3 seconds to enter the program mode. Release the two keys. The display will then be alternately flashing “tunE” and “oFF”. Press the ▼ key once. The display will then be alternately flashing “LEVL” and “1”. Press and hold the ★ key. Press the ▲ key once to move to level 2. Release the two keys. Press and hold the ▲ key until “SP2.A” appears. Press and hold the ★ key. Press the ▲ key until the display reads FS.Lo. Release the two keys. The display will then be alternately flashing “SP2.A” and “FS.Lo”.
 - b **Save configuration into memory** - Press and hold ▲ and ▼ keys simultaneously for 3 seconds. The display will then be alternately flashing the process temperature and “PARk” indicating that no setpoint temperature has been entered.
- 3 *Set the control setpoint and auto-tune the controller.*
 - a **Input the control setpoint temperature** - Press and hold the ★ key. Hold the ▲ key until the display goes from 0 to 65.
 - b **Auto-tune the controller** - Press and hold ▲ and ▼ keys simultaneously for 3 seconds to enter the program mode. Release the two keys. The display will then be alternately flashing “tunE” and “oFF”. Press and hold the ★ key. Press the ▲ key until “At.SP” appears. Release the two keys. Press and hold ▲ and ▼ keys simultaneously for 3

seconds to exit the program mode. The display will then be alternately flashing “**tunE**”, “**At.SP**” and the actual process temperature. Allow the controller time to auto-tune. *When tuning* is complete the display will show **only** the actual process temperature. This process may take up to an hour.

4 *Enable low temperature alarm.*

- a **Input the alarm setpoint** - Press and hold the ▼ key until “**LEVL**” appears. Press and hold the ★ key. Press the ▼ key to move to level 1. Release the two keys. Press and hold the ▲ key until “**Set.2**” appears. Press and hold the ★ key. Press the ▲ key until “**32**” appears. Release the two keys. This alarm will control the sample pump so that it will automatically turn off at any time that the temperature is below 32°C.

Appendix D – Drawings

Cutsheet Drawing

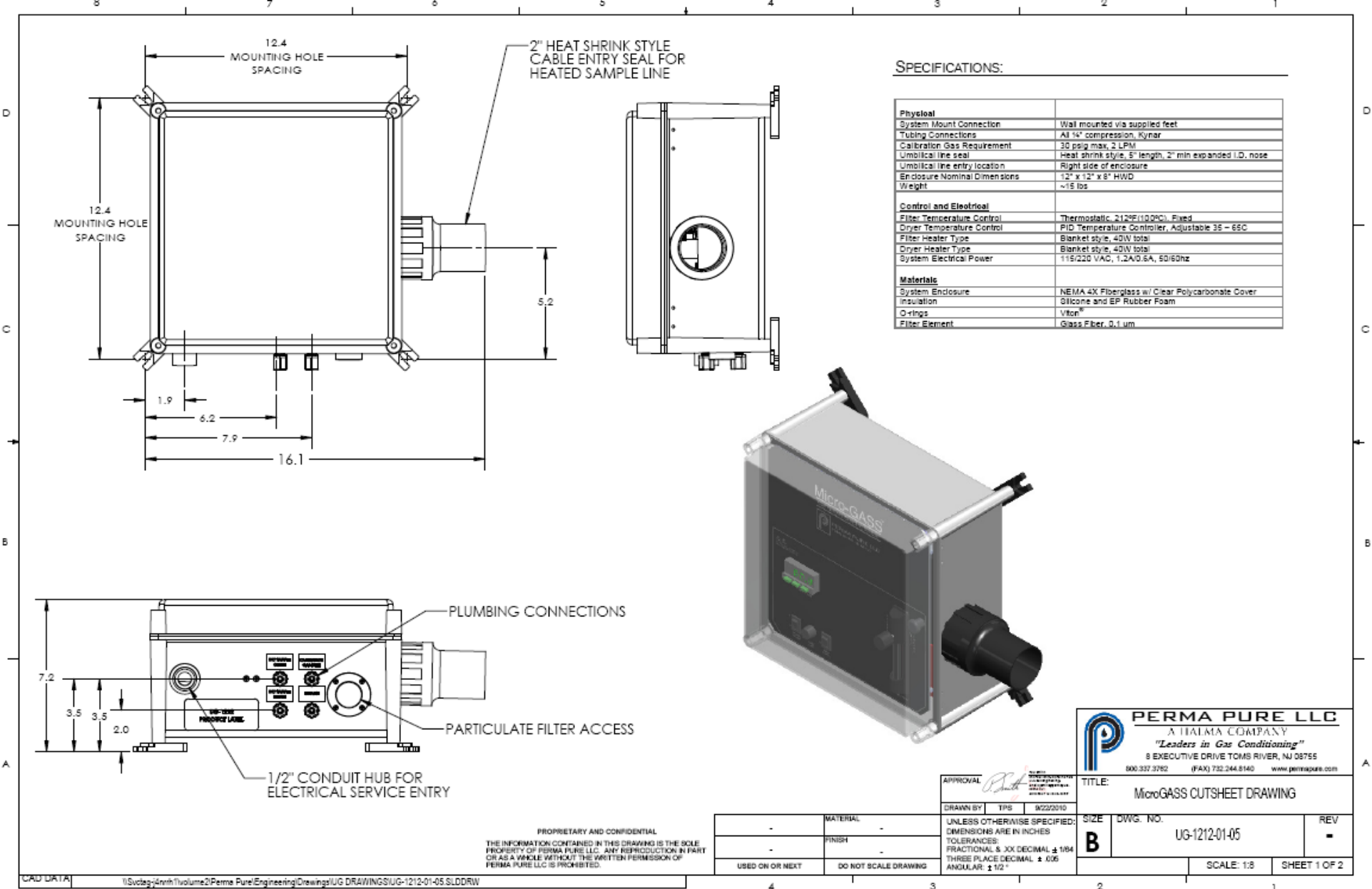

Electrical Diagram

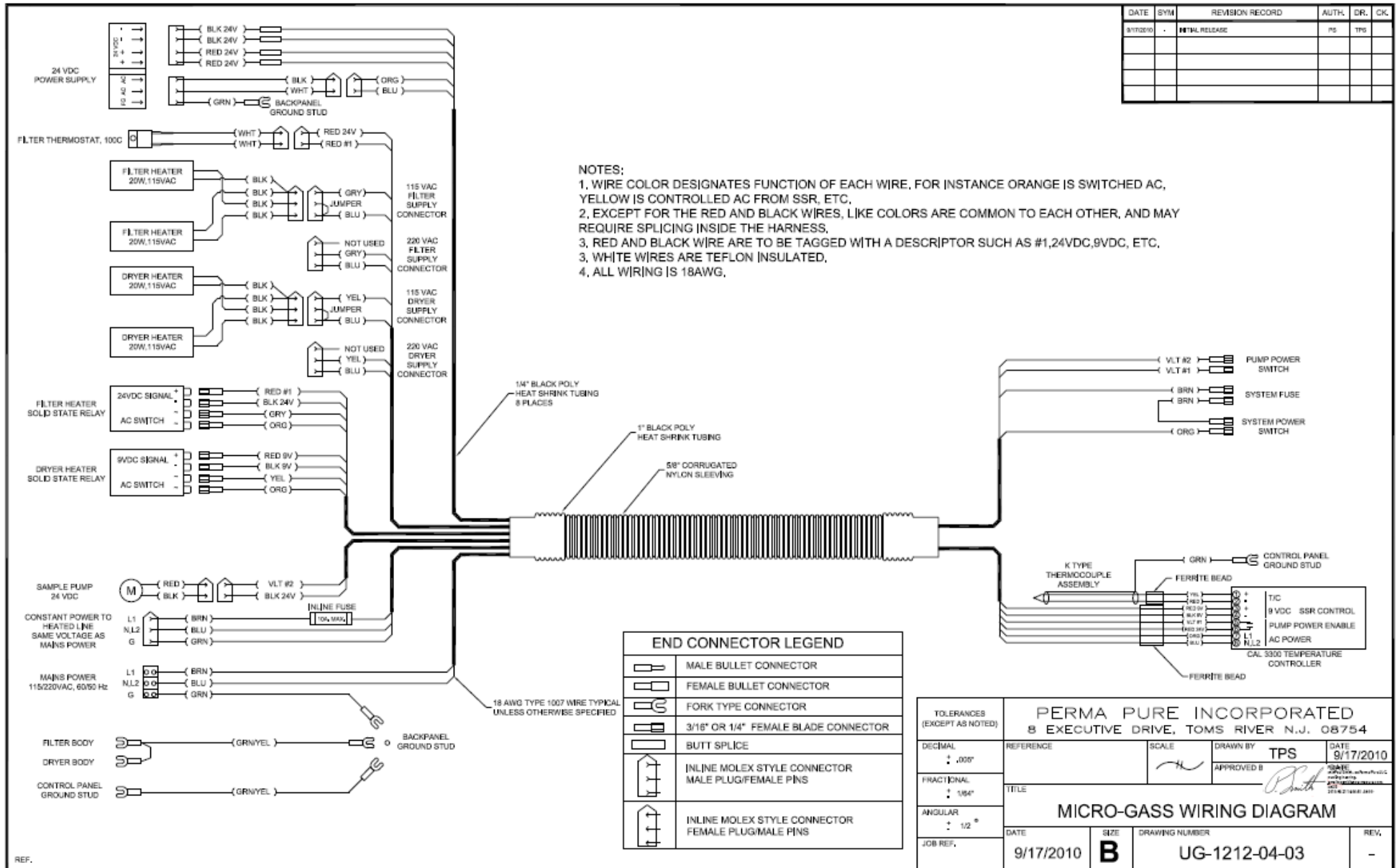

Flow Diagram

DATE	SYM	REVISION RECORD	AUTH.	DR.	CK.
7/14/00	A	UPDATED TO SHOW ENCLOSURE	PS	EA	
9/22/2010	B	Revised to reflect new version	PS	TPS	

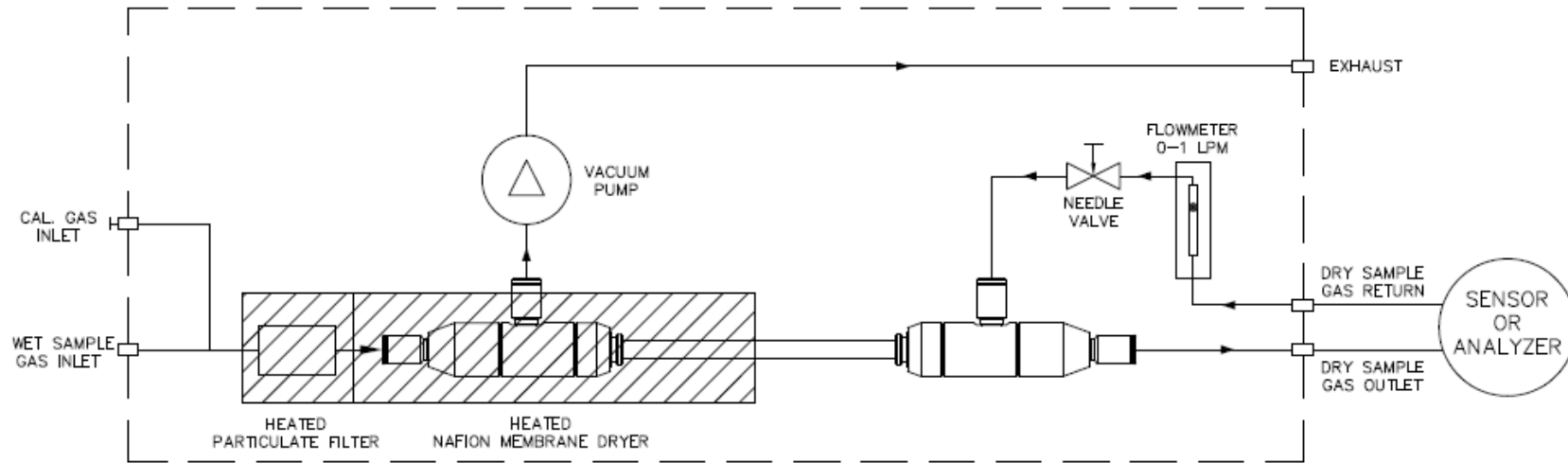

TOLERANCES (EXCEPT AS NOTED)		PERMA PURE INCORPORATED 8 EXECUTIVE DRIVE, TOMS RIVER N.J. 08754			
DECIMAL $\pm .005"$	REFERENCE	SCALE <i>[Signature]</i>	DRAWN BY TPS	DATE 9/22/2010	<small> Approved by: O. Smith, on Perma Pure LLC, on Engineering email: osmith@permapure.com 2010.09.27 15:55:58 -0400 </small>
FRACTIONAL $\pm 1/64"$	TITLE MICRO-GASS FLOW DIAGRAM		APPROVED BY <i>[Signature]</i>		
ANGULAR $\pm 1/2^\circ$	DATE 8/13/99	SIZE A	DRAWING NUMBER UG-1212-01-01	REV. B	
JOB REF.					