

Zero-Air™ Generator

Eliminate Compressed Gas Cylinders, Bring Zero Air to the Point of Use

Perma Pure Zero-Air™ generators produce purified air at rates up to 18 liters per minute with just a flip of a switch. Components treated include CO, NOx, SOx, water vapor, hydrocarbons, acid vapors, and bacteria. Best of all, the unit is totally self-contained in a convenient, lightweight portable case. Zero-Air generators convert ambient air into clean air that meets the Federal Register definition of zero air, suitable for instrument calibration.

Key Features

- 18 lpm of zero air
- Nafion™ dryer technology
- UV sterilization
- Organics scrubber
- Fully self-contained
- Portable
- Eliminates cylinder gas
- Compact and rugged

Principle of Operation

Zero-Air generators require only a standard 110 or 220 VAC outlet to operate. An internal PD Series Nafion™ gas dryer dries the air to a 0°C dew point or better, depending on pressure and flow settings. A fixed purge stream is produced by expanding a portion of the dried gas exiting the dryer. The internal compressor supplies up to 18 liters per minute of air. The maximum pressure of the air is internally regulated to 30 psig. A panel-mounted flow meter and a pressure gauge indicate compressor output

Minimal maintenance is required since there is only one consumable scrubbing compound and one disposable particulate filter needing periodic replacement. Access to all maintenance items is achieved simply by the removal of four screws.



Model	ZA-750-10
Overall Dimensions	8.5" w x 10" h x 16.5" l (216 x 254 x 419 mm)
Weight	27 lbs (12.3 kg)
Power Consumption	110 VAC, 2.5 amps / 220 VAC, 1.25 amps

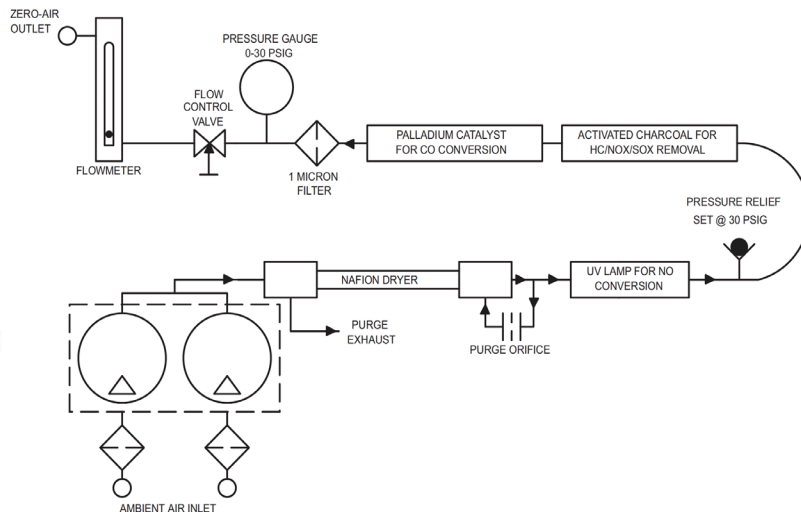
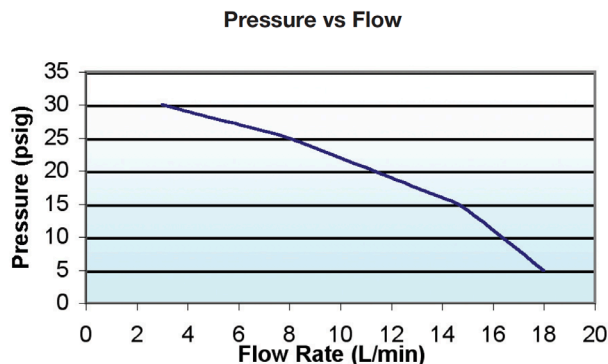

Component	Description
Air Inlet	Dual-head diaphragm pump draws in ambient air. A flow meter and a pressure gauge indicate air supply conditions.
Pre-filter	10µ sintered stainless steel particulate filter.
Dryer	Nafion™ tube membrane dryer removes moisture.
Dryer Purge Gas	The air stream exiting the dryer splits, a portion expands through an orifice and is used as a purge source for the dryer.
Sterilization	Ultraviolet light is an ozone generator used to sterilize.
Oxidizer	The UV light is also an oxidizer, converting NO into NO ₂ .
CO Converter	Palladium catalyst converts the CO to CO ₂ .
Scrubber	Activated carbon scrubber removes any hydrocarbons and acid vapors present in the air stream.
NOx Scrubber	An indicating catalyst blended within the carbon scrubber removes NOx. This catalyst changes from purple to brown and ultimately to white as its capacity is exhausted.
Final Filter	Before exiting the system, the air flows through a 0.1 micron particulate filter which ensures that there is no desiccant dust carryover from the canisters.

System Specifications	
Nafion™ Gas Dryer	PD-750-12PR
Sterilizer, 254 nm UV Lamp	ZA-UVLAMP
NOx, SOx, HC Scrubber	Activated carbon, indicating catalyst blend, ZA-AR
CO Catalyst	Palladium impregnated alumina, ZA-CO-CANISTER
0.1µ Particulate Filter	DIF-N70

Perma Pure LLC • A Halma Company • info@permapure.com • www.permapure.com

1001 New Hampshire Ave., Lakewood, NJ 08701 USA

Lit. No.: Zero-Air-Flyer-1802 Supersedes: New

©2018 Perma Pure LLC. All rights reserved. Specifications subject to change.

Nafion™ is a registered trademark of The Chemours Company.