

Zero-Air™ Generator

User's Manual



PERMA PURE LLC

A HALMA COMPANY

8 Executive Drive • P.O. Box 2105 • Toms River, NJ 08754

Contents

Unpacking	3
Introduction	3
General description	4
Specifications and features.....	5
Important safety warnings	5
Start-up procedure	6
Maintenance	7
Activated carbon/alumina replacement	7
Final filter replacement.....	8
Fuse replacement	8
Replacement parts.....	8
Appendix A: Warranty and disclaimers.....	9
Appendix B: Wiring diagrams	10



Unpacking

Perma Pure has made every effort to ship you a high quality product that has been thoroughly inspected and tested. It has been carefully packed to ensure that it arrives at your facility in good condition. Even though every effort has been made to prevent damage during the transportation process, damage can occur by the carrier. This is out of control of Perma Pure and is the responsibility of the carrier to ensure that your equipment arrives intact and undamaged.

- ❖ Inspect outside packaging. If there is any visible damage, inform the carrier at the time of deliver. ***This inspection is important! Once the package is signed for, responsibility for any visible damage then transfers to the consignee.***
- ❖ Unpack your equipment. Visually inspect the outside of your equipment for any damage. If there is any damage, ***contact the carrier immediately.*** Generally, a carrier must be notified within 24 hours of the delivery to make a hidden damage claim.

Items in the carton include:

- (1) Zero-Air Generator
- (1) User's Manual

If any of the above parts are missing or damaged, call the helpline at **(800) 337-3762 ext-145.**

Introduction

Thank you for purchasing this product from Perma Pure LLC. This manual has been assembled so that it can answer all questions regarding operation. Please keep the operators manual near the equipment for future reference. There may also be optional equipment available that was not ordered at the time of original purchase, which may be described and/or illustrated in this manual.

If you still have any questions regarding your equipment's operation, available options or technical support, please contact your purchasing dealer or contact Perma Pure directly.

Perma Pure LLC
P.O. Box 2105
8 Executive Drive
Toms River, NJ 08754
website: www.permapure.com

Tel: 732-244-0010
Tel: 800-337-3762 (toll free US)
Fax: 732-244-8140
e-mail: info@permapure.com

General description

Perma Pure's portable Zero-Air generator (ZAG) is a light-weight, self-contained system capable of producing 18 lpm of high purity, particle free dry air. The dual head diaphragm pump draws ambient air into the ZAG where it is compressed then purified using a combination of membranes, adsorbents, and filters as shown in figure 1.

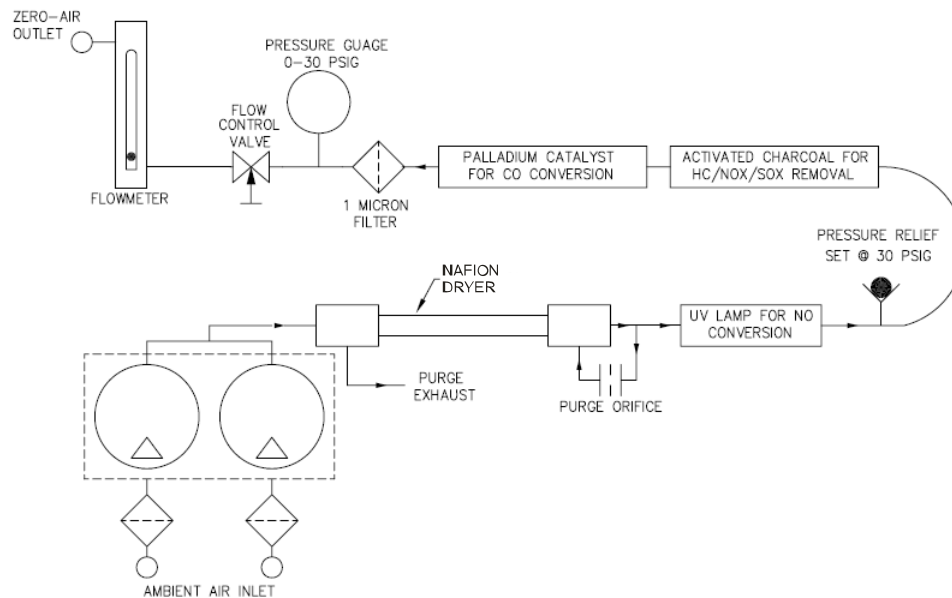

Figure 1 - ZAG Schematic

Components

Pump – A dual head diaphragm pump draws in ambient air up to 18 lpm at 30 psig. A flow meter and pressure gauge indicate air supply conditions.

Nafion® Dryer – A Nafion membrane dryer removes water vapor and certain polar organic compounds (ie. Alcohols, ketones). A bundle of Nafion tubes is housed inside a dryer shell. As wet compressed air flows through the tubes, water vapors is absorbed through the membrane and carried off by a counter-current purge air.

Ultraviolet Lamp – The UV lamp produces approximately 1-3 ppm of ozone, which breaks down microorganisms into carbon compounds that are removed further downstream. It also oxidizes NO to NO₂ which is removed a system adsorbents.

Activated carbon/Alumina mixture – This is a blend of activated carbon and impregnated alumina pellets. The mixture will remove trace quantities of chlorine (Cl₂), hydrogen fluoride (HF), hydrogen sulfide (H₂S), nitrogen oxides (NO_x), ozone (O₃), sulfur dioxide(SO₂), sulfur trioxide (SO₃) and general hydrocarbons (HC). The mixture changes from purple to brown, indicating the need for replacement.

Carbon monoxide catalyst – Palladium impregnated alumina pellets are used to convert low levels of CO to CO₂. This catalyst is not consumable, and should last the lifetime of the unit.

Particulate filter – Last stage of purification is the particulate filter. This filter has an absolute retention rating of 1 micron, and 93% rating for particles down to 0.1 micron. The disposable filter is housed in a transparent plastic housing, allowing easy visual determination of the filter's condition.



Specifications and features

- Pump: Dual head diaphragm, up to 30 psig, 18 slpm
- Inlet filter: Sintered SST, 10 micron porosity
- Dryer: PD-100T-12MZA Nafion® gas dryer
- Sterilizer: Ultraviolet light chamber, 254 nm peak wavelength
- NOx, SOx, HC scrubber: Activated carbon, indicating catalyst blend, 0.7 lbs.
- CO catalyst: Palladium impregnated alumina
- Final filter: 0.1 micron glass fiber particulate filter

- Operating environment: -20°C to 40°C ambient temp.; 0-95% RH; Altitude up to 2000 m
- Electrical requirements: 115 VAC ±10%
- Dimensions: 8.5" W x 10" H x 16.5" L (216 x 254 x 419 mm)
- Weight: 27 pounds (12.3 kg)

Important safety warnings

Please be sure to review the following basic safety procedures. These procedures represent the MINIMUM requirements to operate the equipment safely. It is the ultimate responsibility of the operator to ensure proper safety practices are utilized at the point of operation. This equipment is to be installed & operated by trained personnel, with sufficient command of the English language to clearly understand the instructions & safety warnings.

- This equipment is **NOT** designed to operate in a wet environment.
- **NEVER operate the equipment with any part of the enclosure unsecured.** All operated covers must be in place and secured prior to operation. Electrical current may be present behind covers, even if tools are not necessary to access these components.
- **NEVER** attempt service on this equipment without first disconnecting all energy sources. Repair of this equipment should only be done by properly trained personnel that are familiar with the potential risks involved with servicing of the equipment.
- **NEVER** replace fuses with types other than the sample specification of type and current. Do not bypass this or any other safety device.
- **NEVER** operate this equipment if it is visibly damaged or the possibility exists that it may have been damaged.
- The use of components that have not been purchased through an authorized Perma Pure dealer or directly from Perma Pure may compromise the safety of the operator. Additionally, use of non-authorized components may change the operating characteristics of this equipment. Any changes to the equipment, that modify its operation in any way, are dangerous, and are strictly prohibited.
- Read the entire operating manual before attempting to set up or operate the equipment.
- Please heed all warning labels that are on the equipment. They are there to remind you of possible hazardous conditions.
- Verify the integrity of any mechanical and/or electrical connections that are made to the unit.
- Verify that the unit is connected to the proper rated power for the system.
- Verify that the unit is plumbed properly to operate effectively.

Start-up procedure

1. Place ZAG on level, dry surface.
2. Check to make sure power switch is in "OFF" position.
3. Plug unit into standard 115VAC electrical outlet.
4. Turn flow control knob counter-clockwise to open fully.
5. Connect calibration gas line to ¼" tube compression fitting located on top panel of generator.
6. Turn power switch to "ON" position.
7. Adjust flow control valve to desired air output. Maximum capacity is 18 lpm.
8. High purity air will be produced within 23 minutes after start-up.

NOTE: There is a trade off between air pressure and flow. High air volumes will result in lower air pressure, and vice versa (see figure 3).

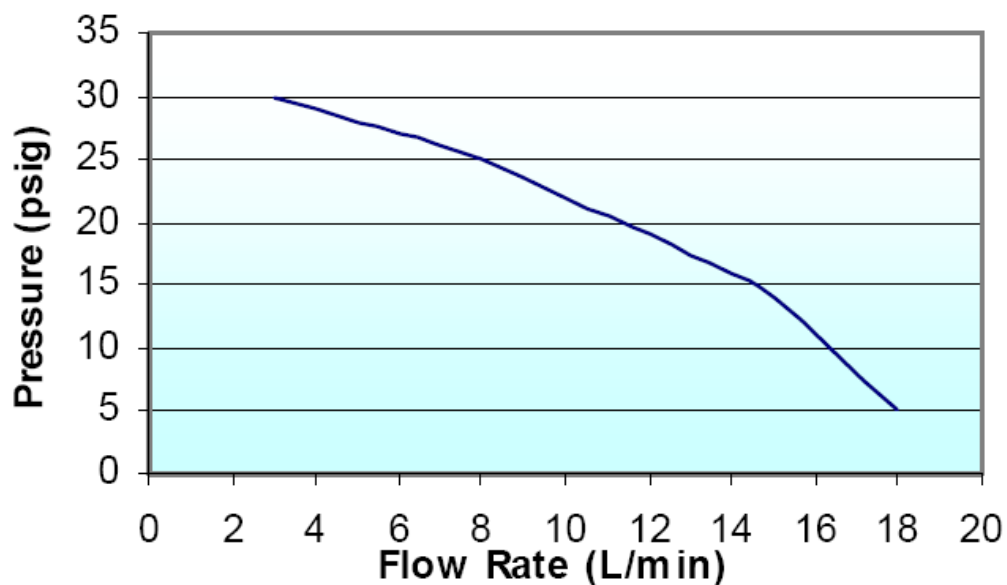

Figure 3 - Flow rate vs pressure curve



Maintenance

WARNING !!

De-pressureize and unplug the ZAG before attempting any maintenance or removing the top or bottom panels!

Routine maintenance consists of periodic carbon replacement and outlet filter replacement. Under normal, intermittent use, desiccant should last up to six months.

Activated carbon/alumina replacement

Activated carbon canister is located behind top panel. Top half of canister is exposed to allow visual inspection of mixture. As the mixture is used, its color changes from purple to brown. When $\frac{3}{4}$ of the canister has changed to brown, replace mixture. The mixture can not be regenerated and must be discarded.

Replacing the mixture

1. Place towel or cloth across bottom panel to prevent scratches.
2. Disengage four (4) panel screws by turning $\frac{1}{4}$ turn counterclockwise.
3. Pull panel out and lay down on top of bottom panel.
4. Unscrew nuts off brackets.
5. Detach tubing by loosening compression fittings using $\frac{5}{8}$ " wrench.
6. Remove canister from panel.
7. Remove bottom black plug using $\frac{7}{8}$ " wrench.
8. Pour out pellets while tapping canister lightly.
9. Re-fill canister by slowly pouring in fresh activated carbon/impregnated alumina mixture.
10. Tap side of canister while filing to settle mixture and reduce air pockets.
11. Apply Teflon® tape to the plug and replace in bottom of canister and tighten.
12. Reverse procedure to install canister to ZAG.

Final filter replacement

The final particulate filter should be replaced each time the activated carbon canister is changed. The filter is located immediately after outlet of CO catalyst canister.

1. Loosen the four (4) panel screws by turning ¼ turn counterclockwise.
2. Pull top panel out. Note orientation of filter so that it can be installed the same way.
3. Loosen ¼" compression nuts on either end and pull filter from tubing.
4. Remove nuts from old filter and place them on new filter.
5. Install new filter with the standoff end (visible inside housing, supporting filter element) connected to catalyst canister outlet.
6. Firmly tighten compression nuts on inlet and outlet tubing.

Fuse replacement

If unit fails to run when plugged in and turned on, first check the fuse.

1. Disconnect power cord from power input module on bottom panel of unit.
2. Using slotted tip screwdriver, pry up at slot located inside cord entry socket, about ¼" below surface of power input module. This will pull up fuse carrier that holds the fuse and a spare.
3. Inspect fuse to see if it is blown. If so, remove it and replace it with spare fuse.
4. If fuse is in good shape, re-install and plug system back in.

If unit does not work, unplug it and remove four socket head screws located on corners of bottom panel. Pull bottom panel out and inspect wiring connections to make sure they are secure. If any loose wires are evident, tighten the connection if possible. Refer to wiring schematic in Appendix B.

Replacement parts

PD-100T-12MZA	Replacement membrane dryer
ZA-AR	Purafil activated carbon absorbent, one refill
DIF-N70	Filter replacement, 0.1 micron glass fiber particulate



Appendix A: Warranty and disclaimers

Perma Pure LLC

Perma Pure (Seller) warrants that product supplied hereunder shall, at the time of delivery to Buyer, conform to the published specifications of Seller and be free from defects in material and workmanship under normal use and service. Seller's sole obligation and liability under this warranty is limited to the repair or replacement at its factory, at Seller's option, of any such product which proves defective within one year after the date of original shipment from seller's factory (or for a normal usable lifetime if the product is a disposable or expendable item) and is found to be defective in material or workmanship by Seller's inspection.

Buyer agrees that (1) any technical advice, information, suggestions, or recommendations given to Buyer by Seller or any representative of Seller with respect to the product or the suitability or desirability of the product for an particular use or application are based solely on the general knowledge of Seller, are intended for information guidance only, and do not constitute any representation or warranty by Seller that the product shall in fact be suitable or desirable for any particular use or application; (2) Buyer takes sole responsibility for the use and applications to which the product is put and Buyer shall conduct all testing and analysis necessary to validate the use and application to which Buyer puts the product for which Buyer may recommend the use or application of the product by others; and (3) the characteristics, specifications, and/or properties of the product may be affected by the processing, treatment, handling, and/or manufacturing of the product by Buyer or others and Seller takes no responsibility for the nature or consequence of such operations or as to the suitability of the product for the purposes intended to be used by Buyer or others after being subjected to such operations.

SELLER MAKES NO OTHER WARRANTY, EXPRESS OR IMPLIED, OF THE PRODUCT SUPPLIED HEREUNDER, INCLUDING, WITHOUT LIMITATION, IMPLIED WARRANTIES OF MERCHANTABILITY AND FITNESS FOR PARTICULAR PURPOSE, AND ALL SUCH WARRANTIES ARE HEREBY EXPRESSLY EXCLUDED. SELLER SHALL HAVE NO LIABILITY FOR LOSS OF PROFITS, OR SPECIAL, INCIDENTAL, OR CONSEQUENTIAL DAMAGES UNDER ANY CIRCUMSTANCES OR LEGAL THEORY, WHETHER BASED ON NEGLIGENCE, BREACH OF WARRANTY, STRICT LIABILITY, TORT, CONTRACT, OR OTHERWISE. SELLER SHALL IN NO EVENT BE LIABLE IN RESPECT OF THIS ORDER AND OR PRODUCT DELIVERED ON ACCOUNT OF THIS ORDER FOR ANY AMOUNT GREATER THAN THAT PAID TO SELLER ON ACCOUNT OF THIS ORDER.

Appendix B: Wiring diagrams

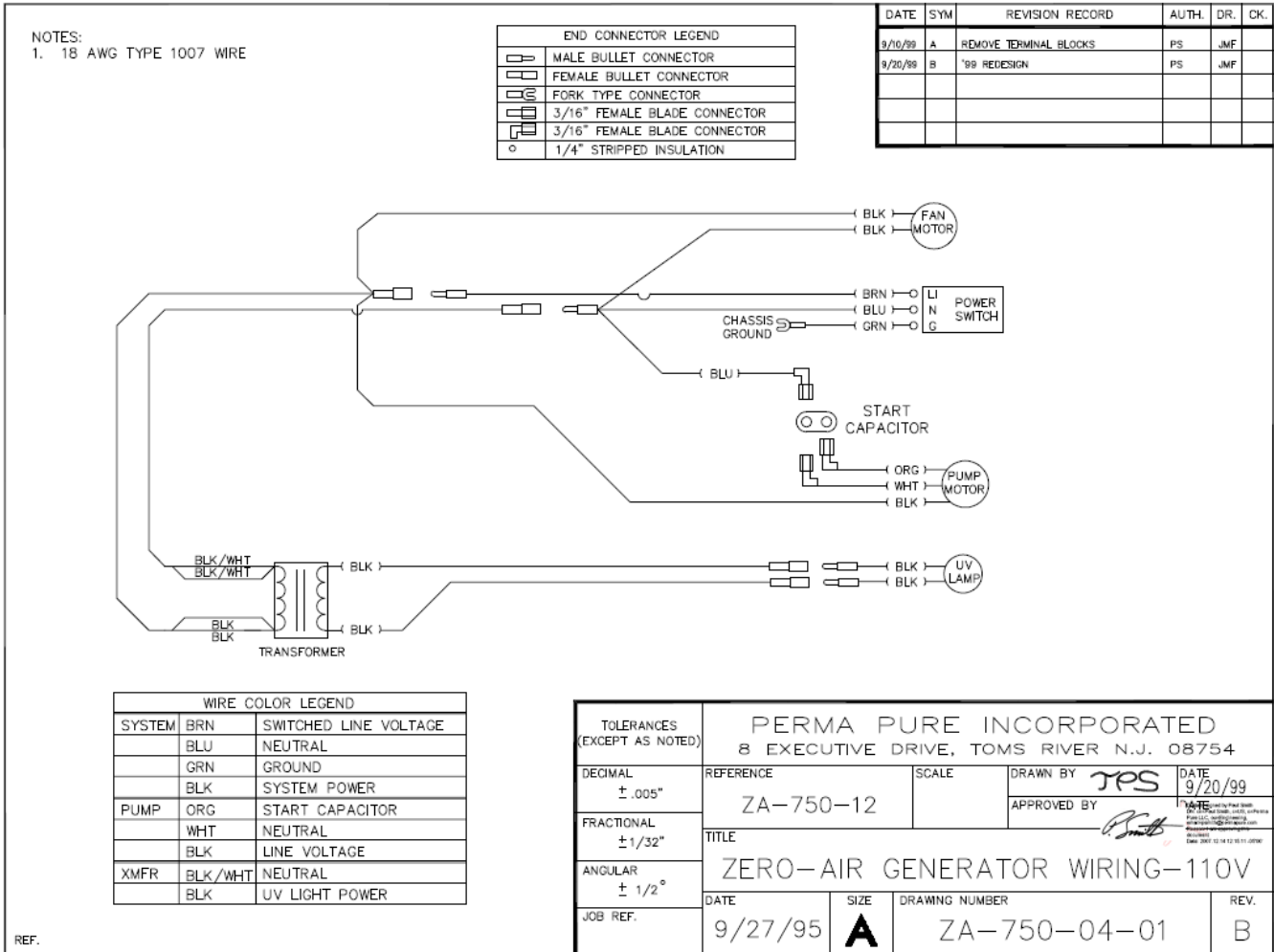

Figure 4 -Wiring diagram 115 VAC